

PMT absolute calibration using the Rayleigh scattering in Nitrogen air

ICRR N. Sakurai, M. Fukushima

Utah University L. Wiencke



Motivation

- **Absolute calibration of PMT**
 - Laser energy can be measured by energy meter precisely.
 - **Rayleigh scattering** is well understood.
(Theory & Experiment)
 - So, we can obtain the precise number of scattering photons by Rayleigh scattering and it can be used for **PMT Q.E.xC.E. calibration**.
 - Hamamatsu estimates the systematic errors of their C.E. and Q.E. measurement as 10%.
(14% in total)



- When we succeed the absolute photonics calibration,
 - The systematic errors of Q.E.xC.E. can be measured by ourselves.
 - Air fluorescence yield is measured by well calibrated PMT. (Laser → Electron)
 - We use well calibrated laser for air fluorescence detector calibration.



Setup

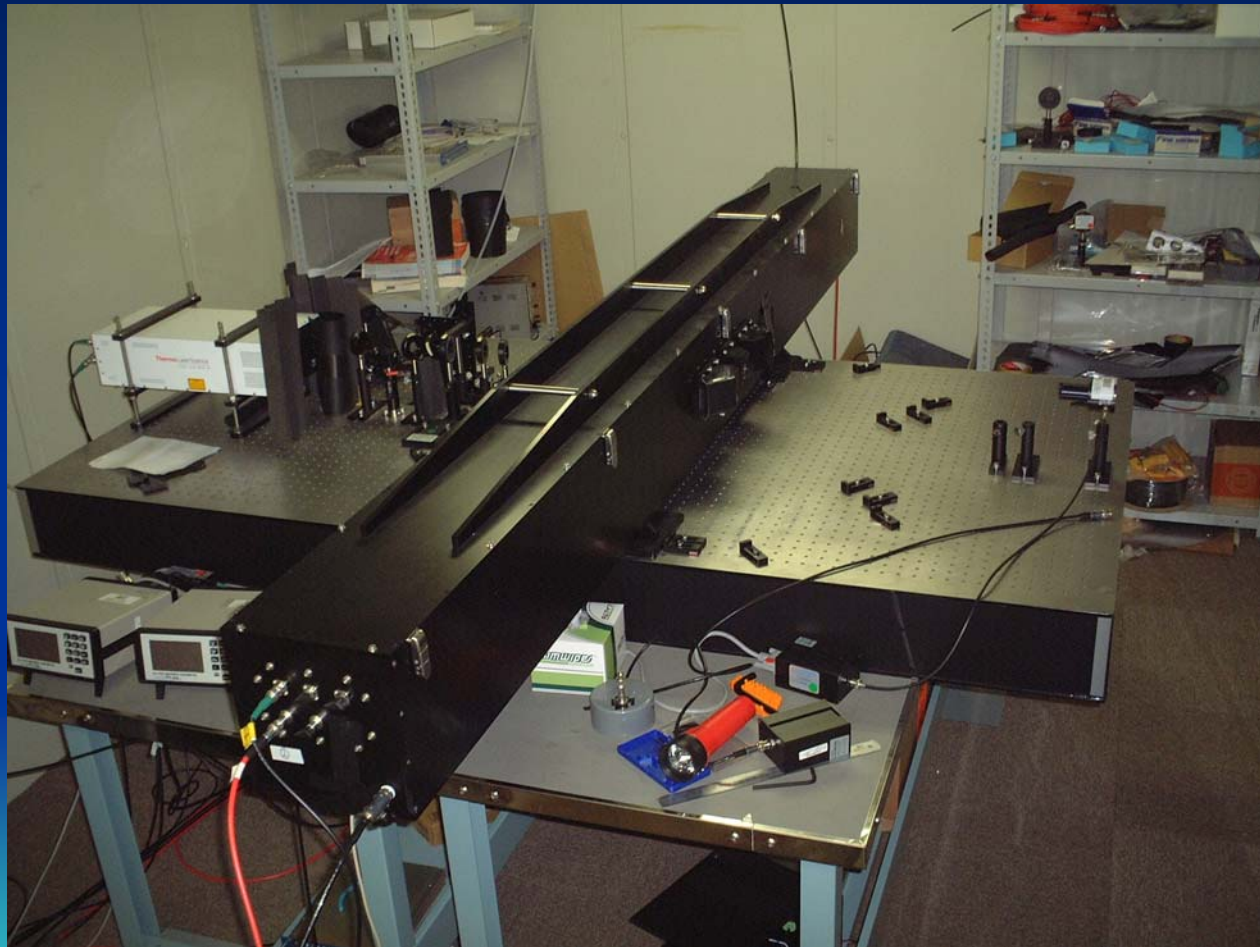

System overview

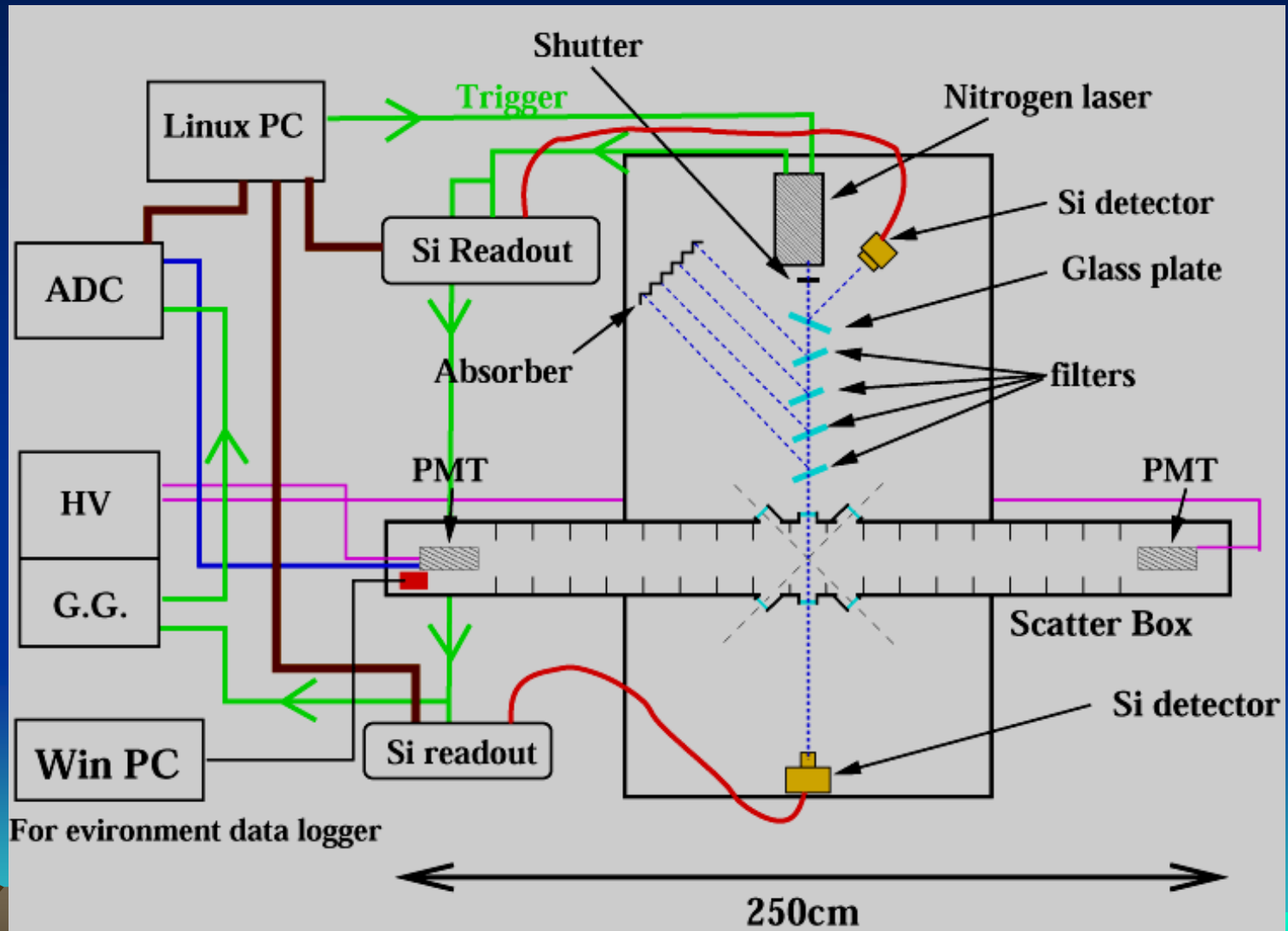

Components

- **Light source**

(Laser Science VSL-337ND-S)

N₂ laser

$\lambda = 337.1\text{nm}$

$E_{\text{max}} = 300\text{uJ}$ (for 1p.e., $E \sim 2\text{nJ}$)

Pulse width $< 4\text{nsec}$



- **Si energy probe**

(Laser Probe Inc. RjP-465)

500fJ-250nJ

Detection area: 1.0cm²

Accuracy = $\pm 5\%$



- **PMT(H7195PX)**

- Size of photo cathode = 60mm phi
- PMTs are calibrated by Hamamatsu.
(Only 25mm phi @center)

(Both of the errors of HPK Q.E. and C.E. are 10%.)

	Q.E.	C.E.
Ch1	25.96%	74%
Ch2	25.78%	77%

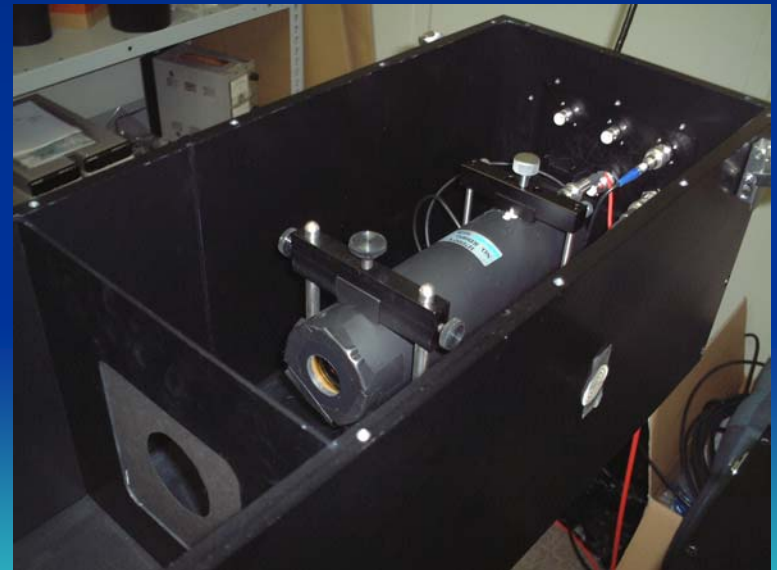

- **Scatter box**

- Size: 25cm x 25cm x 250cm (156litter)
- 8 baffles are installed in front of each PMT.
- They prevents the photons reflected by inside wall entering the PMT.
- Window: CaF_2 with anti-reflection coat
- Transparency of window for 337nm is 99.7%.

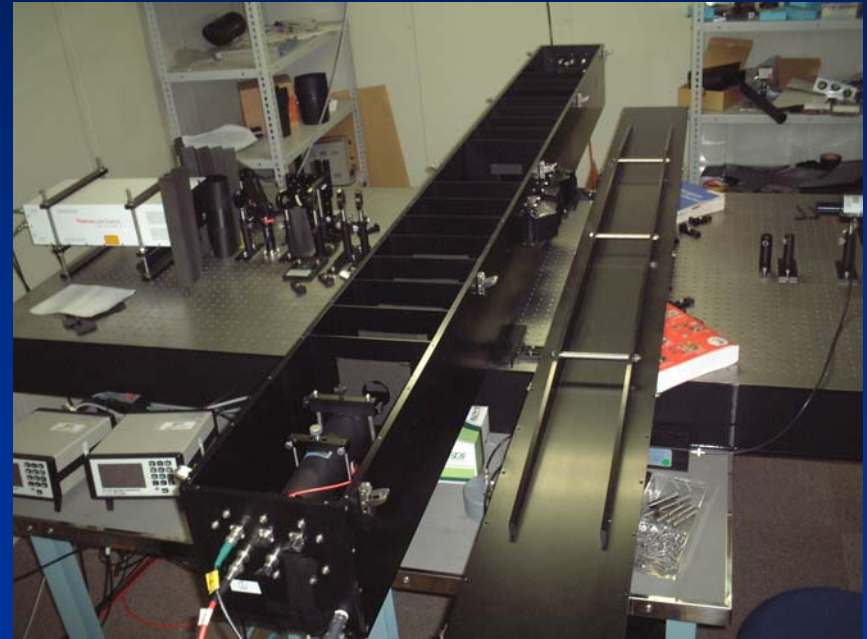

- We can change the incident angle of laser to check mie scattering contamination. (45, 90, 135deg.)
- To reduce the light reflected by the edge of baffles, we put thin papers.

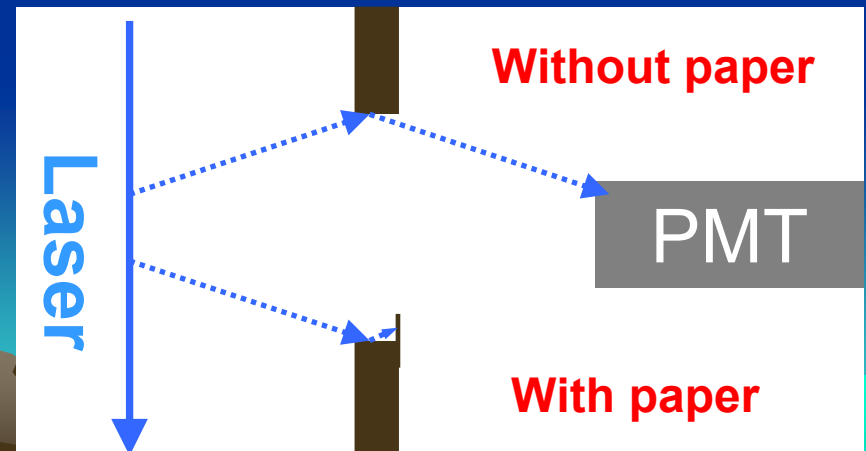

- Pure molecule gas
 - Pure N₂ gas (99.9995%) is used.
 - Flow rate is 5 – 10 liter/min.
 - Temperature and pressure is monitored by environmental data logger.
 - The box is not airtight. So pressure is almost 1atm.
 - Temperature is almost room temperature.
 - After 1 hour of gas exchange, calibration is started.
 - Gas quality is checked by comparing the forward scattering light intensity with the backward scattering one.



Gas quality test

- Rayleigh scattering
 - Forward light = Backward light
- In $t=0\sim 60\text{min}$, forward light $>$ backward light
 - Particles in local air scatter photons by mie scattering(?)

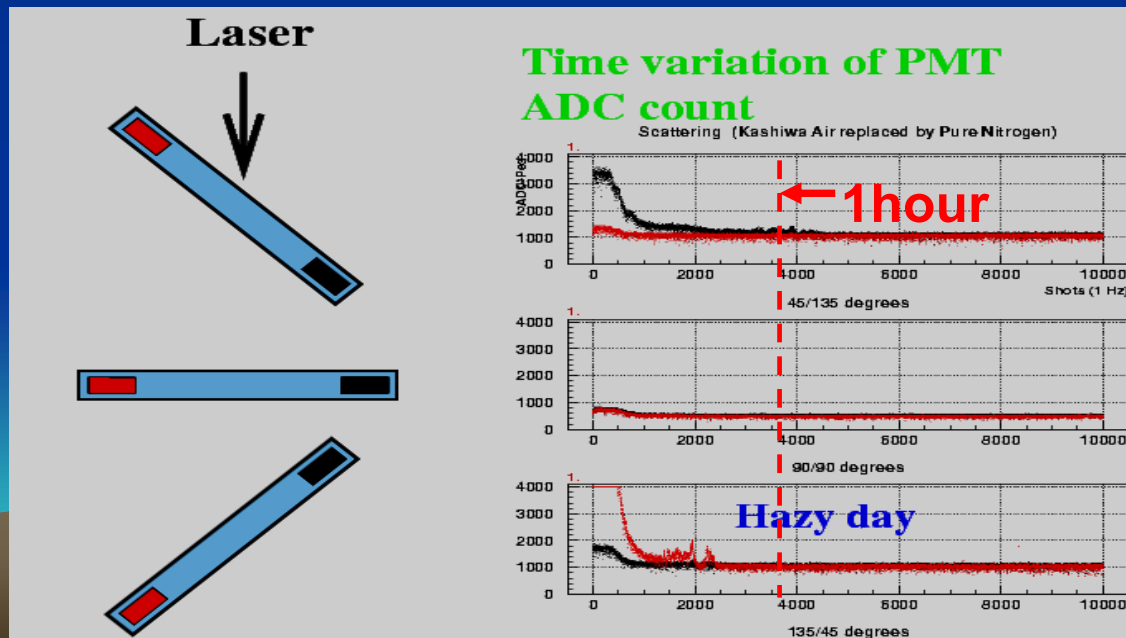

Polarization of laser beam

- Reflective filters put slantwise polarize laser light.
 - ✓ Reflective index depends on the incident angle.
- The angle of polarizer is changed and then laser energy is measured.

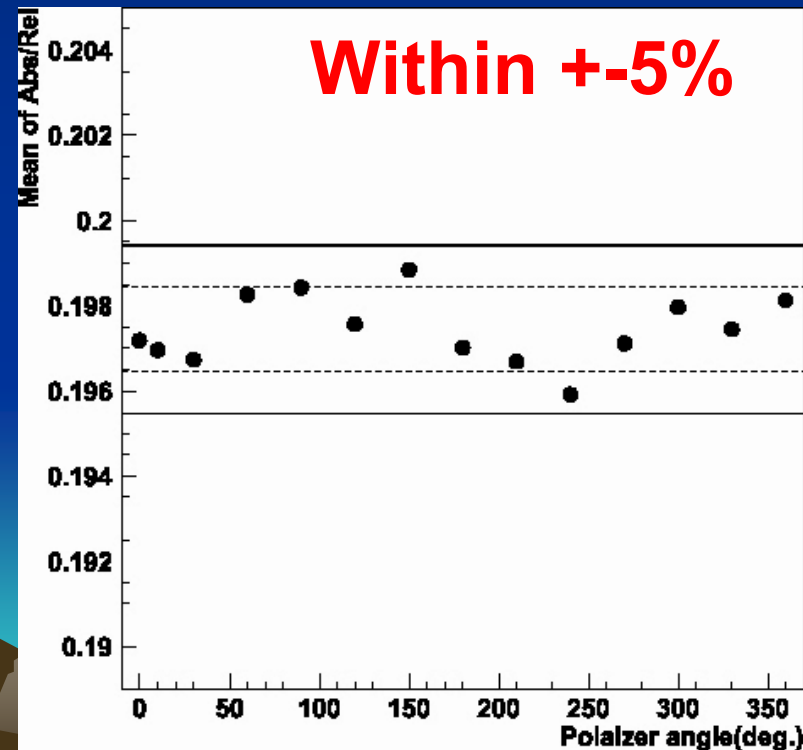
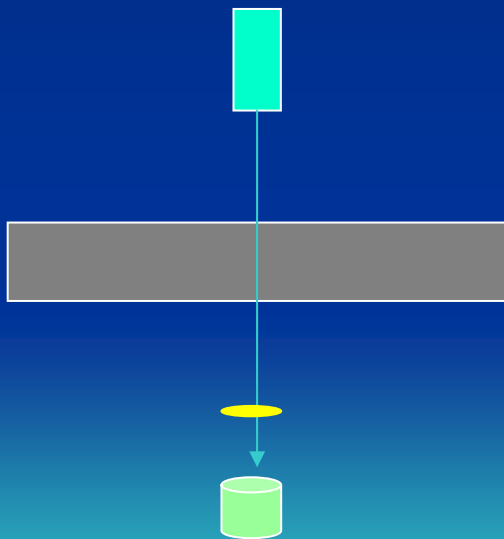

Laser energy cross check

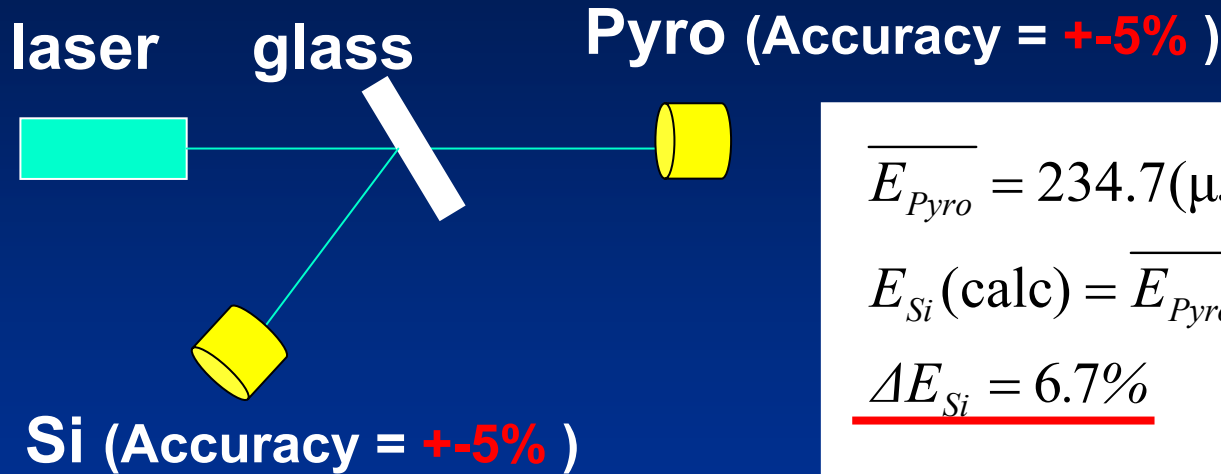

$$\overline{E_{Pyro}} = 234.7(\mu\text{J}), \overline{E_{Si}} = 6.959(\text{nJ})$$

$$E_{Si}(\text{calc}) = \overline{E_{Pyro}} \times R_{Fresnel} = 6.525(\text{nJ})$$

$$\underline{\Delta E_{Si} = 6.7\%}$$

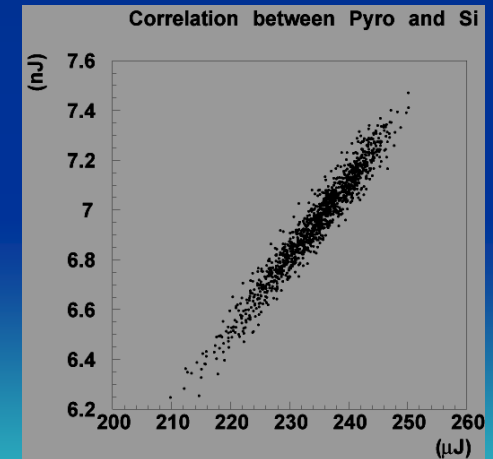
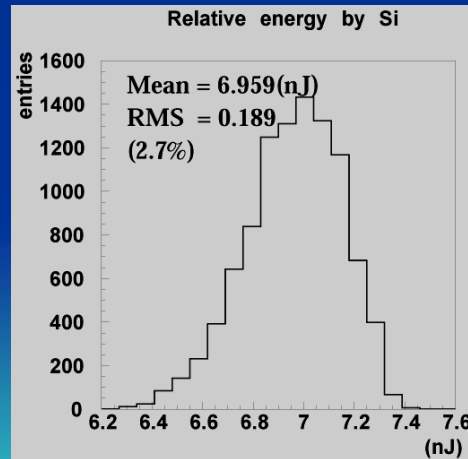
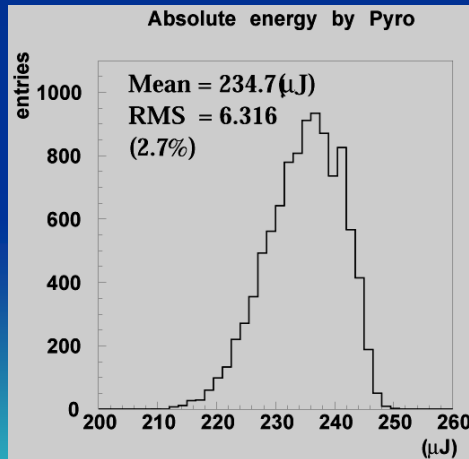

Rayleigh scattering

$$\frac{d\sigma}{d\Omega} = \frac{24\pi^3 (n^2 - 1)^2}{\lambda^4 N^2 (n^2 + 2)^2} F_k \times \frac{3}{16\pi} (1 + \cos^2 \theta)$$

n : refractive index (1.0002936 for stp N_2)

λ : wavelength (337.1nm)

F_k : Correction factor for anisotropy of non-spherical molecules (1.03679 for N_2)

N : number density of molecule
(2.446×10^{19} for stp N_2)

(H.Naus and W.Ubachs, Opt lett, 25 5 347 2000)

- For stp N_2 , $\sigma_{total} = 3.8179 \times 10^{-26} \text{ (cm}^{-2}\text{)}$

Calculation of # of photon in PMT

- N_{pulse} : # of photon in each laser pulse
 - When 1.0uJ, 1.697×10^{12} photon
- N_{mol} : number density of molecule
- A : Acceptance of PMT (include dir. dependence)

$$N_{\text{photon}} = N_{\text{pulse}} \sigma_{\text{total}} N_{\text{mol}} A$$



Calculation of # of photo-electron

ADC distribution

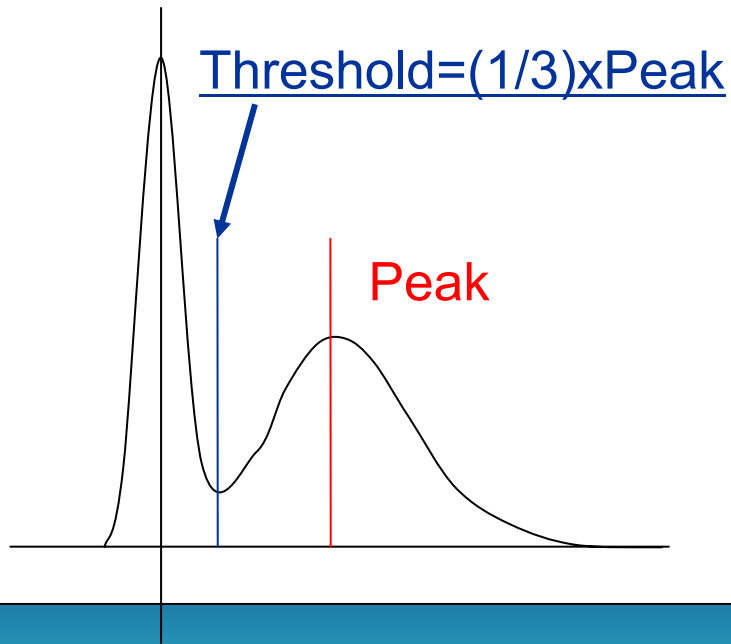

- N_0 : # of events below threshold
- N : # of events above threshold
- μ : average of # of P.E.

$$N_0 = N_{all} \times \exp[-\mu]$$

$$N = N_{all} \times \sum_{i=1}^n \frac{\mu^i \exp[-\mu]}{i!}$$

Absolute calibration: $\theta = 90^\circ$.

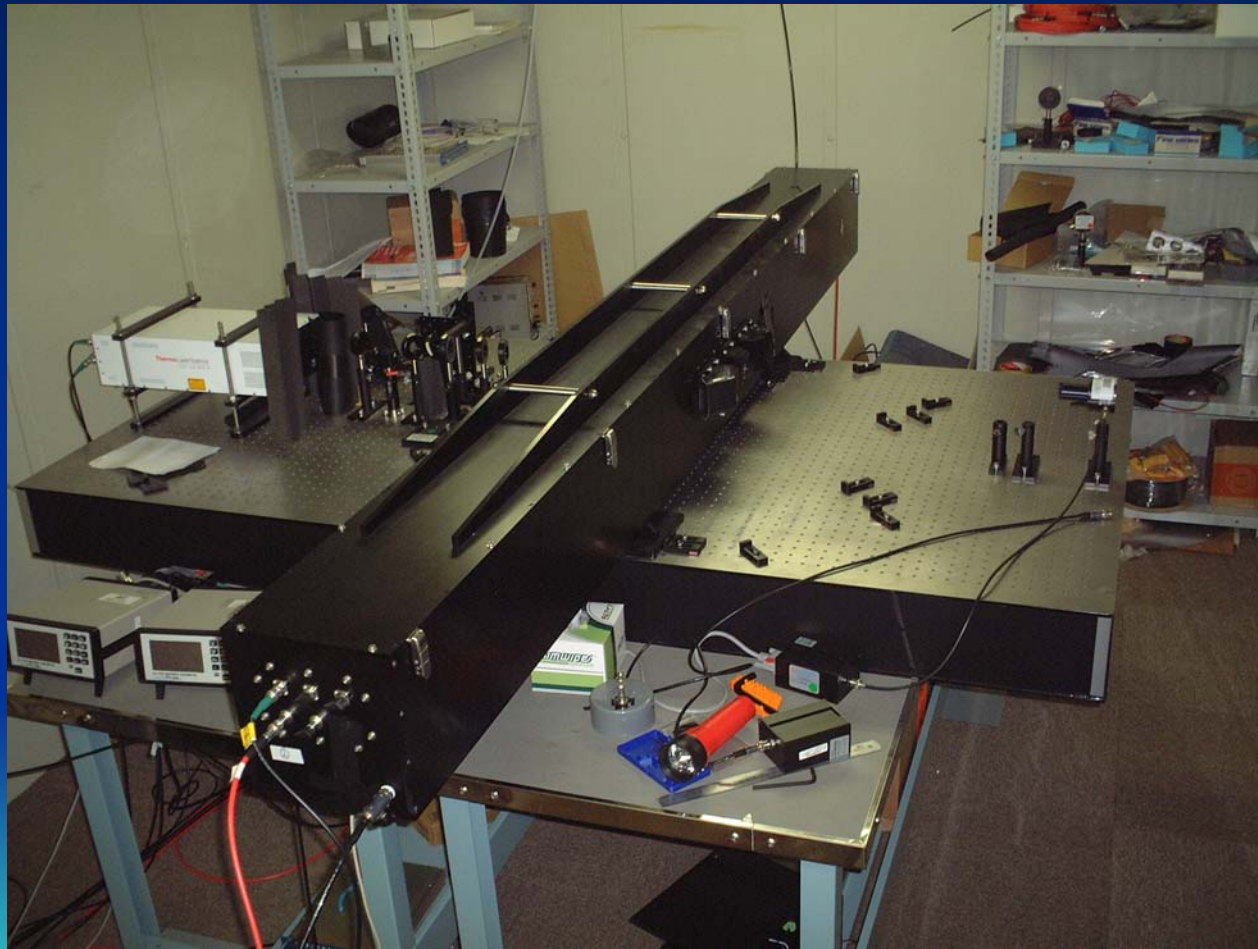

Absolute calibration of PMT1

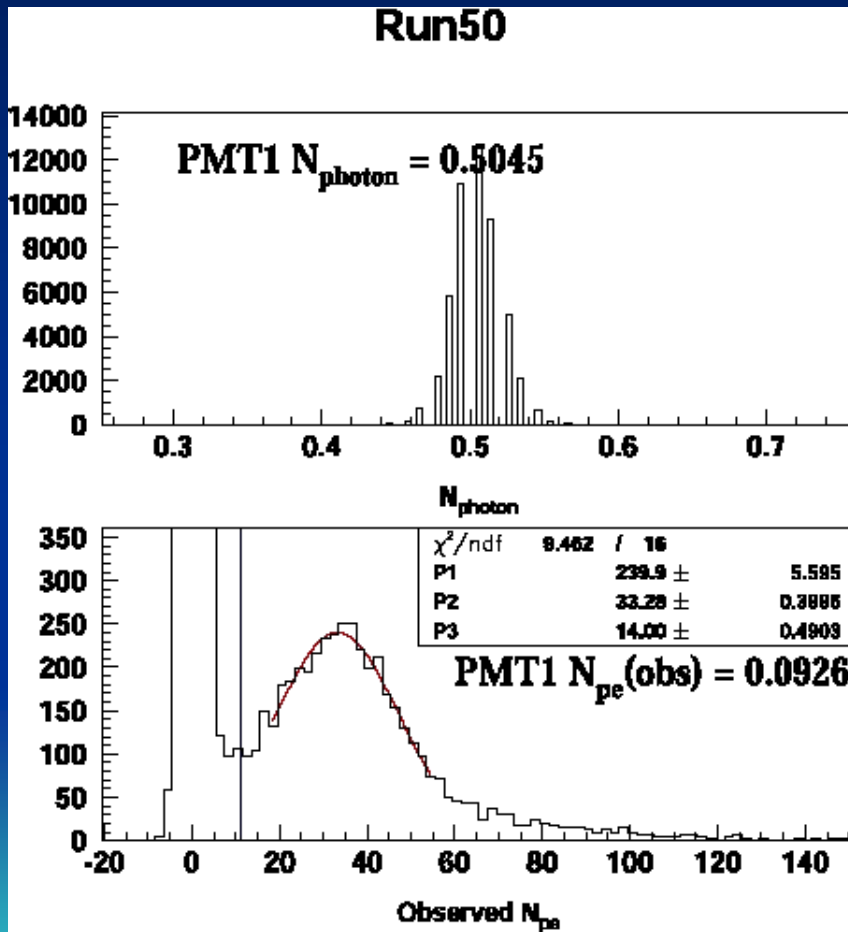

of photon (Si det.)

$$N_{\text{photon}} = 0.50 \pm 0.03$$

of P.E. (PMT)

$$N_{\text{pe}} = 0.093 \pm 0.01$$



$$\text{Q.E.} \times \text{C.E.} = 0.18 \pm 0.02$$

(Data provided by HPK :
 $\text{Q.E.} \times \text{C.E.} = 0.19 \pm 0.03$)

Absolute calibration of PMT2

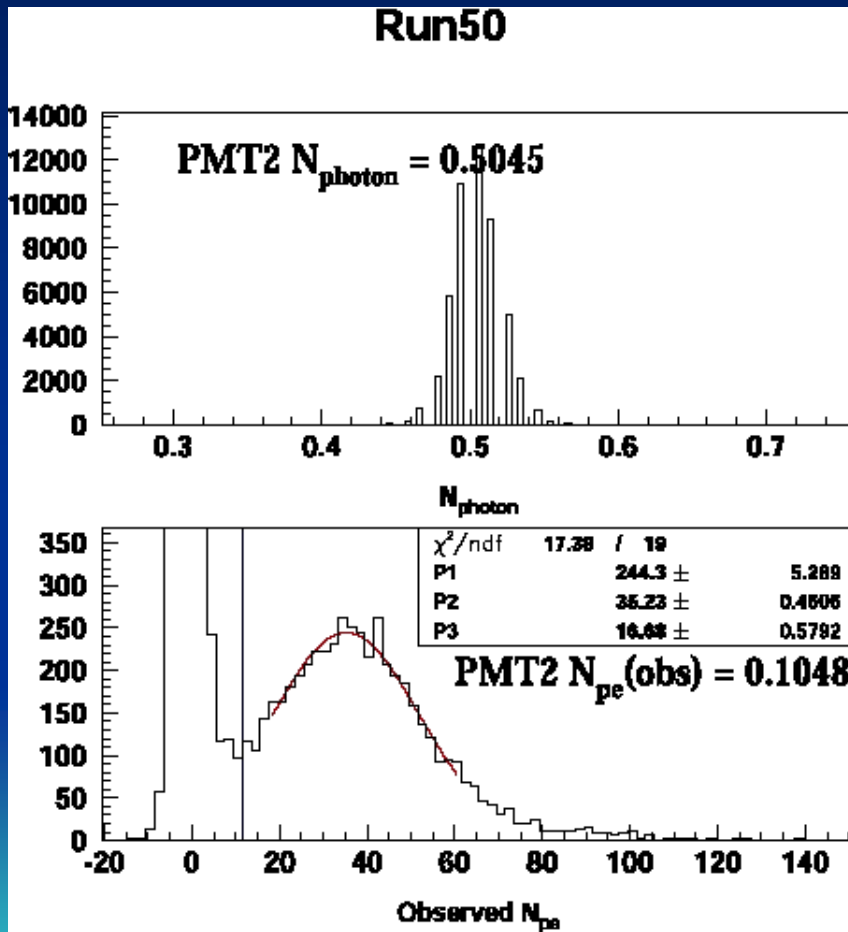

of photon (Si det.)

$$N_{\text{photon}} = 0.50 \pm 0.03$$

of P.E. (PMT)

$$N_{\text{pe}} = 0.11 \pm 0.01$$

→ $Q.E. \times C.E. = 0.21 \pm 0.02$

(Data provided by HPK:
 $Q.E. \times C.E. = 0.21 \pm 0.03$)

Absolute calibration: $\theta = 135^\circ$.



Absolute calibration of PMT1

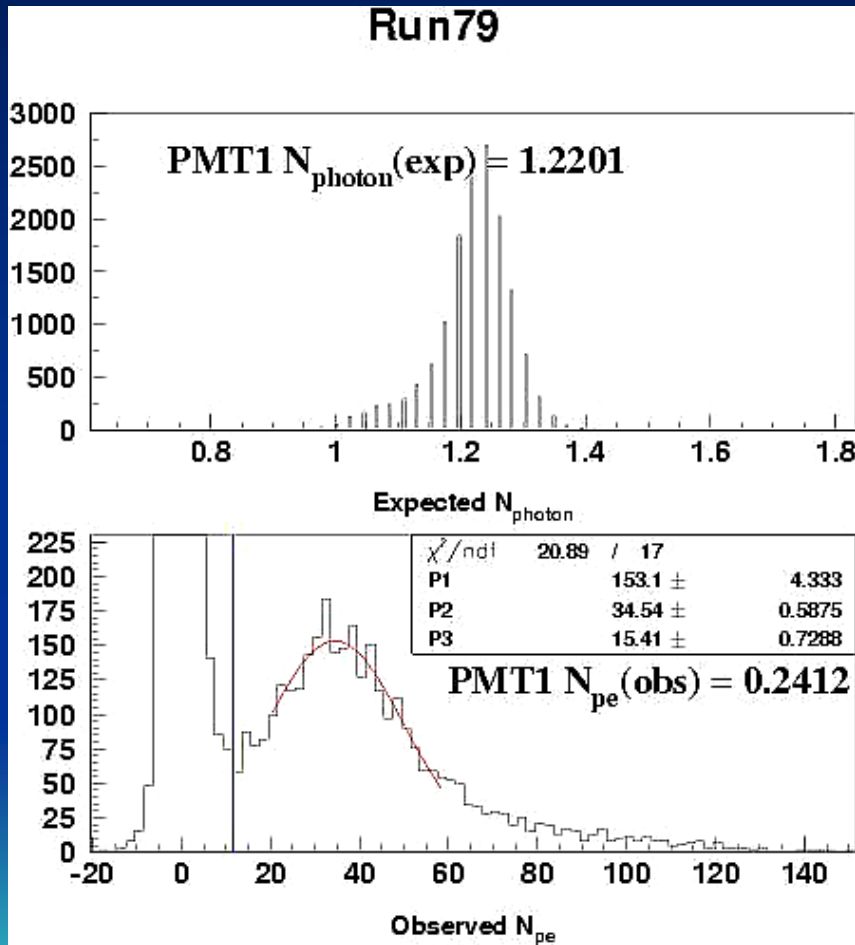

of photon (Si det.)

$$N_{\text{photon}} = 1.22 \pm 0.08$$

of P.E. (PMT)

$$N_{\text{pe}} = 0.24 \pm 0.02$$

→ **Q.E. × C.E. = 0.20 ± 0.02**

(Data provided by HPK :
Q.E. × C.E. = 0.19 ± 0.03)

Absolute calibration of PMT2

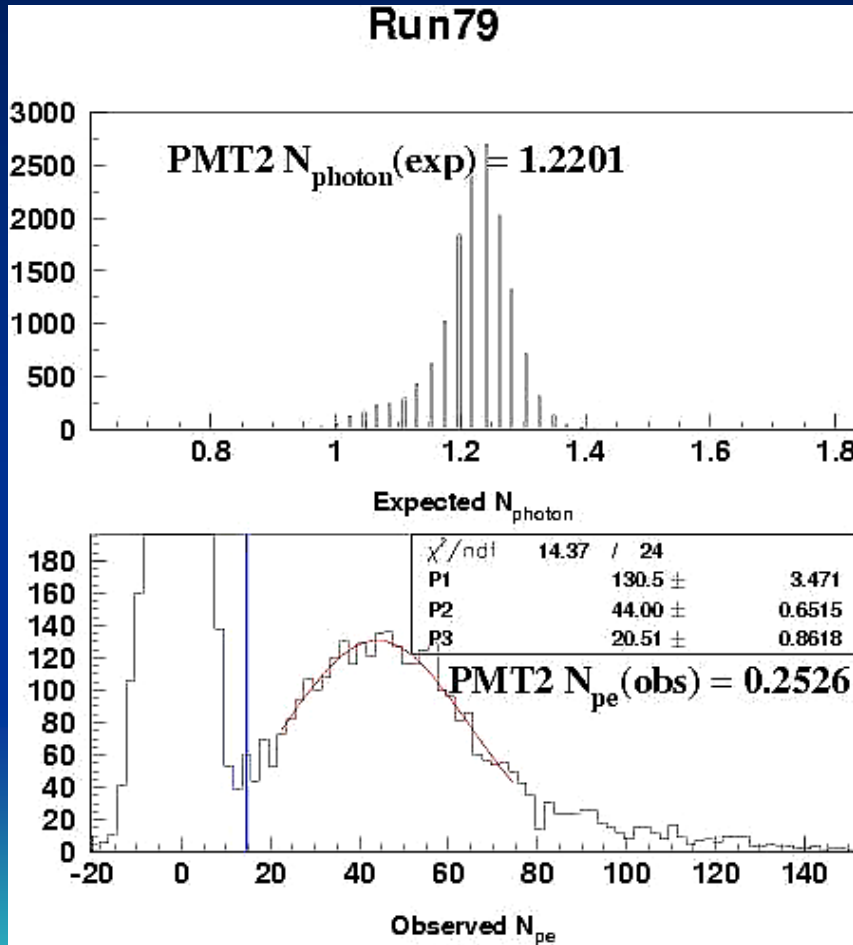

of photon (Si det.)

$$N_{\text{photon}} = 1.22 \pm 0.08$$

of P.E. (PMT)

$$N_{\text{pe}} = 0.25 \pm 0.02$$

→ **Q.E. \times C.E. = 0.21 ± 0.02**

(Data provided by HPK:
Q.E. \times C.E. = 0.21 ± 0.03)

Error estimation (very preliminary)

- Calibration of energy meter : $\pm 5\%$
 - Polarization of beam : $\pm 0.5\%$
 - Acceptance calculation : $\pm 2\%$
 - Scattering cross section : $\pm 3\%$
 - Reflection inside of box : $\pm 2\%$
 - Geomagnetic field : $\pm 8\%$
 - Reproducibility of 1 p.e. : $\pm 8\%$
- # of Photon**
- # of P.E.**



Summary

- PMT absolute calibration method using **Rayleigh scattering by pure gas** is developing.
- Energy of laser is measured by two calibrated energy probes (Pyro-electric and Si), and two results are consistent.
- The measured Q.E.xC.E. is consistent with HPK calibration data.
Systematic error of Q.E.xC.E. is smaller.
- This system will be useful to measure Air fluorescence yield by well calibrated PMT.
(Difference is only electron or photon.)

Future plan

- Now, we start developing new scattering box.
- Easy to change PMTs → Useful to calibrate many PMTs
- To exchange gas, we will use vacuum pump
→ We can easily control the gas quality.

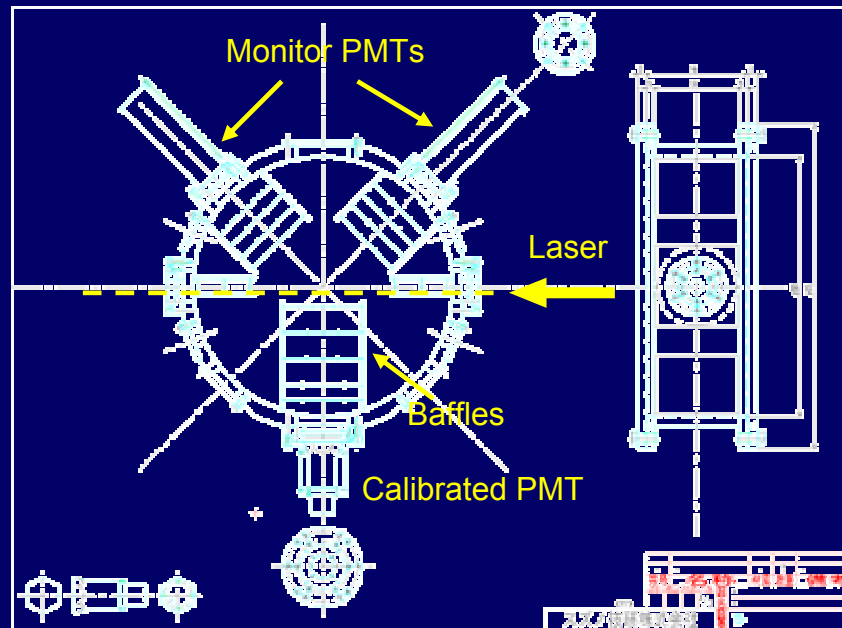

Applications

- Telescope Array PMTs will be calibrated by new apparatus.
 - It will start in February.
- IceCube big PMTs will also be calibrated in this winter.



Other TA calibrations

- The idea of end-to-end calibrations in TA.
 - Vertical laser & tunable laser
 - With calibrated light source, we go around and shoot a beam toward the sky.
 - We can measure trigger aperture and check reconstruction program
 - I think that this is very reasonable idea.
 - Electron LINAC toward the sky.



End-to-end calibration (LINAC)

- First calibration of telescope using real shower
- Beam energy and # of electron can be measured precisely.
- Atmospheric condition does not affect so much.
(Light path is not so long.)

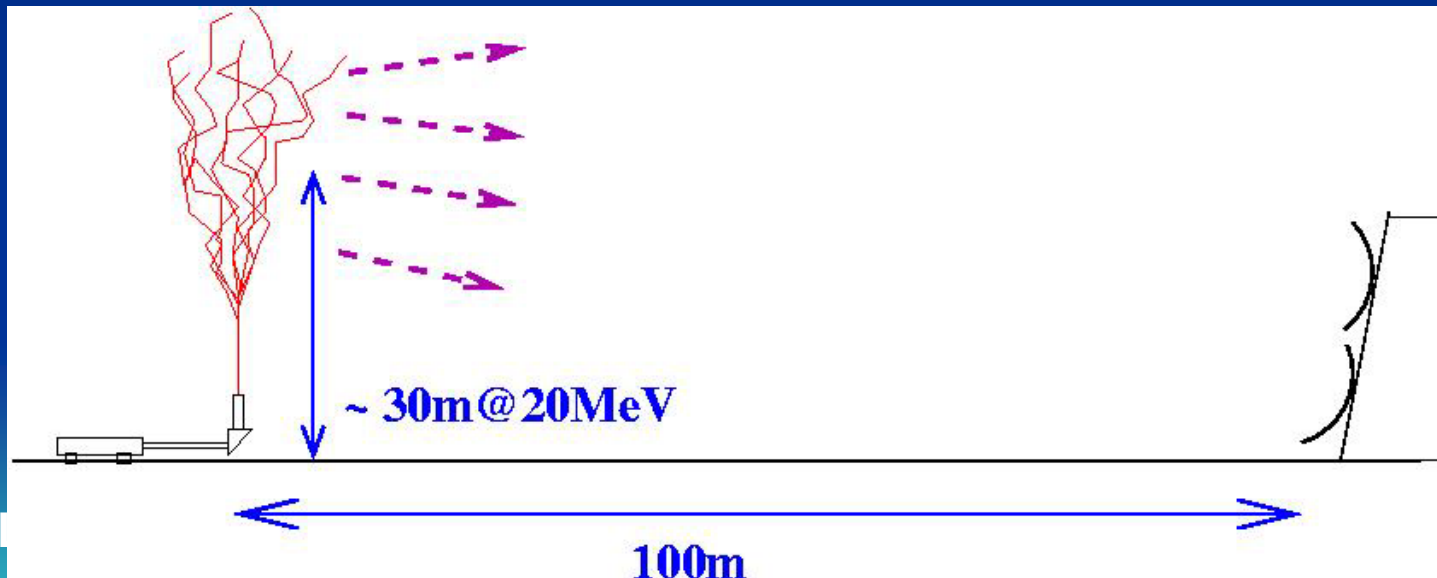
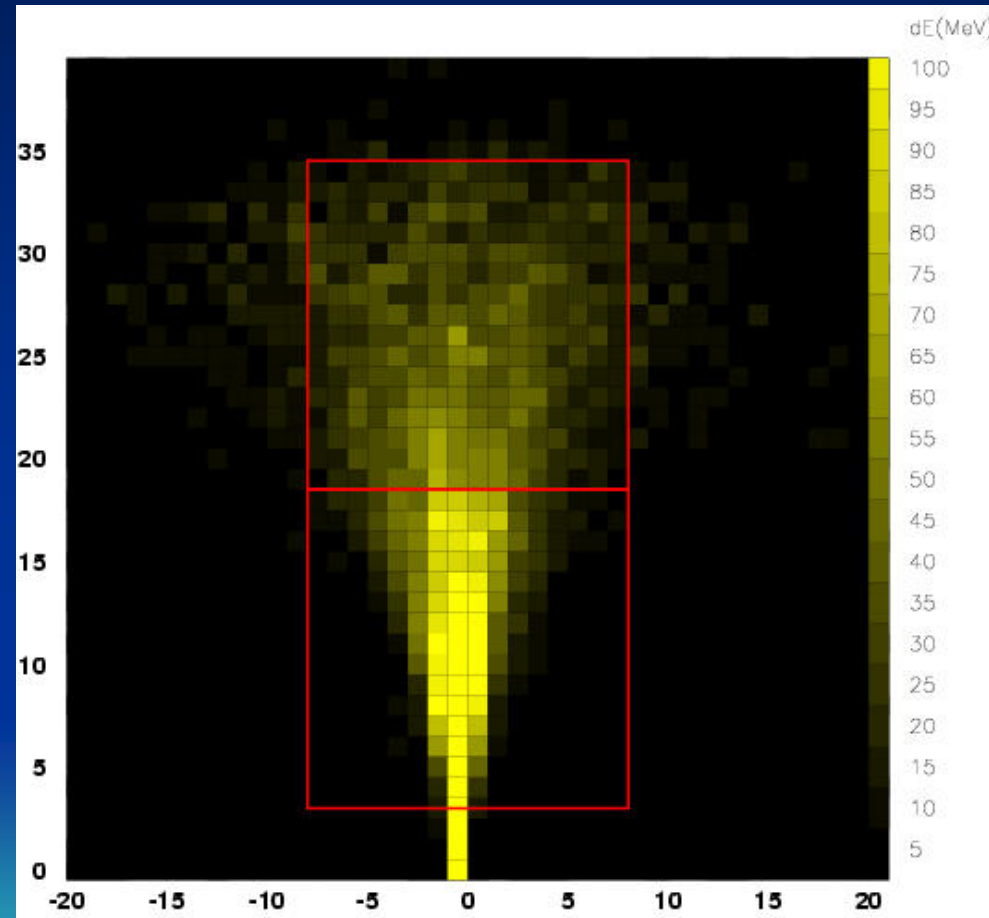

Image of LINAC shower

- **20MeV** electron beam
- **1000 electrons** are displayed in the right figure.
- Red squares show the field of view of 2 cameras.
- Each pixel size corresponds to the FOV of single PMT.
- dE in FOV in two cameras is about **70%** of total energy.



Merit of LINAC calibration

- Systematic error of energy scale is checked directly.
 - For cross check, monochromatic laser (energy calibrated) is shot toward sky.
- Simulation can be easily done using GEANT.
- Trigger and geometry reconstruction efficiency may be measured by this system.



Problems of LINAC calibration

- It isn't understood whether it doesn't violate radiation protection law.
- Is there a suitable place to built LINAC near the telescope station?
- No people, No money.



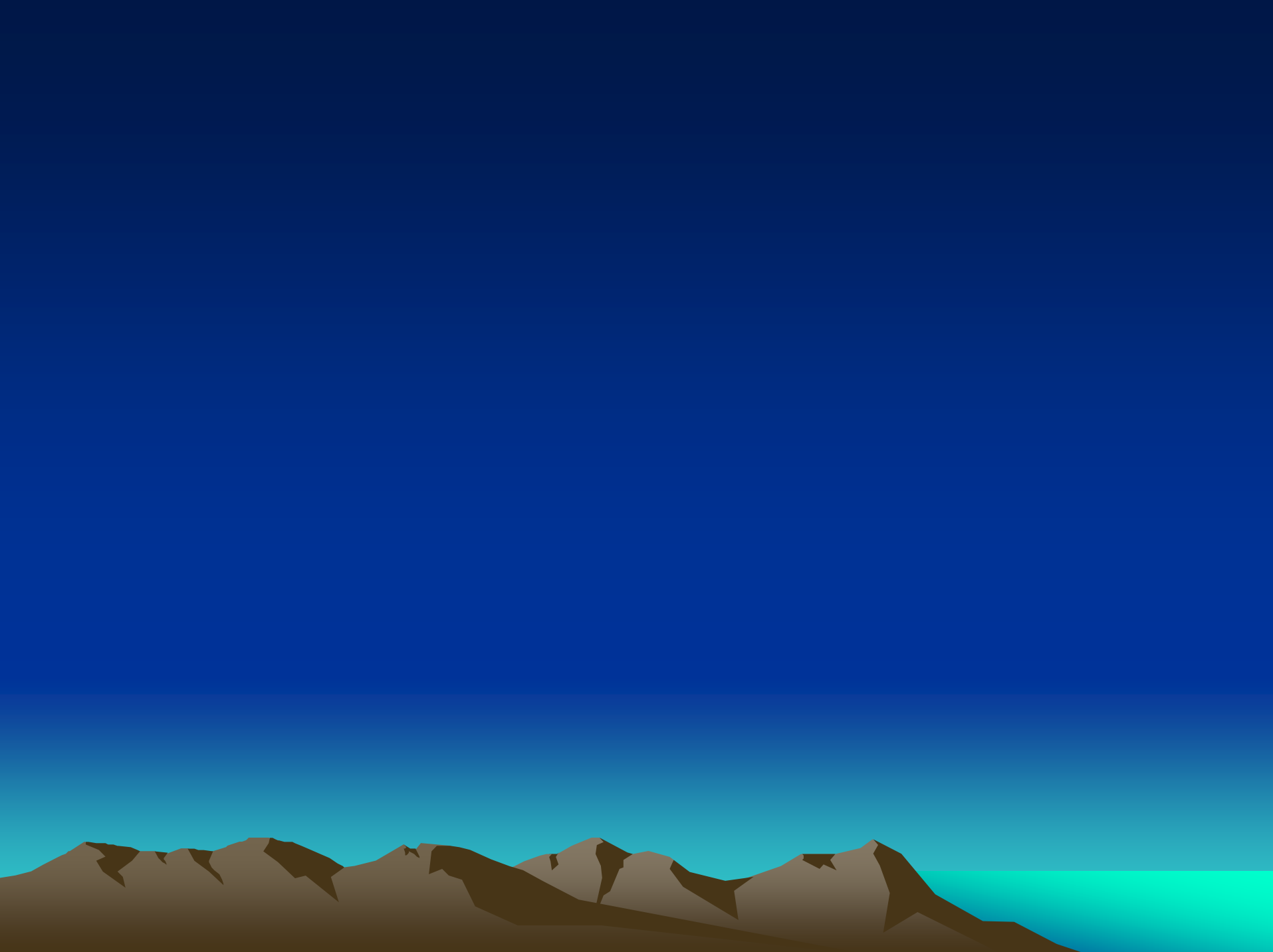

PMT pulse shape

- PMT pulse shape for single photo electron.
 - Vertical lines: 40ns digit
 - Horizontal lines: 20mV

