

# FLASH (SLAC E165)

## Plans and Progress Report on Systematics and Calibration

Petra Hüntemeyer

Air Light 03

Bad Liebenzell, Germany, December 11 - 14, 2003



# How is fluorescence yield defined in the present case?

$$Y(\lambda) = \frac{n_{\phi}(\lambda)}{x \cdot n_{e^{-}}}$$

$n_{\phi}(\lambda)$ :

Number of photons of wavelength  $\lambda$

$x$ :

Distance of travel through air

$n_{e^{-}}$ :

Number of electrons injected in the air target

# Things to consider:

- Two experiments:

1. Main Chamber
2. The Spectrograph

$$\left. \begin{array}{l} 1. \text{ Main Chamber} \\ 2. \text{ The Spectrograph} \end{array} \right\} n_{\phi}(\lambda), X$$

- During the run:

- beam position and shape
- beam charge
- detector response stability

→ Quality cuts

→  $n_{e^{-}}$

→  $n_{\phi}(\lambda)$

- Before/after the run:

- toroid calibration
- chamber/detector calibration

→  $n_{e^{-}}$

→  $n_{\phi}(\lambda), X$

# Outline

- The Main Chamber
- The Beam Charge
- Other Systematic Checks
- Outlook

# THE MAIN CHAMBER

Before installation

# The Main Chamber: Design sketch

$$n_{\phi}(\lambda)$$

X

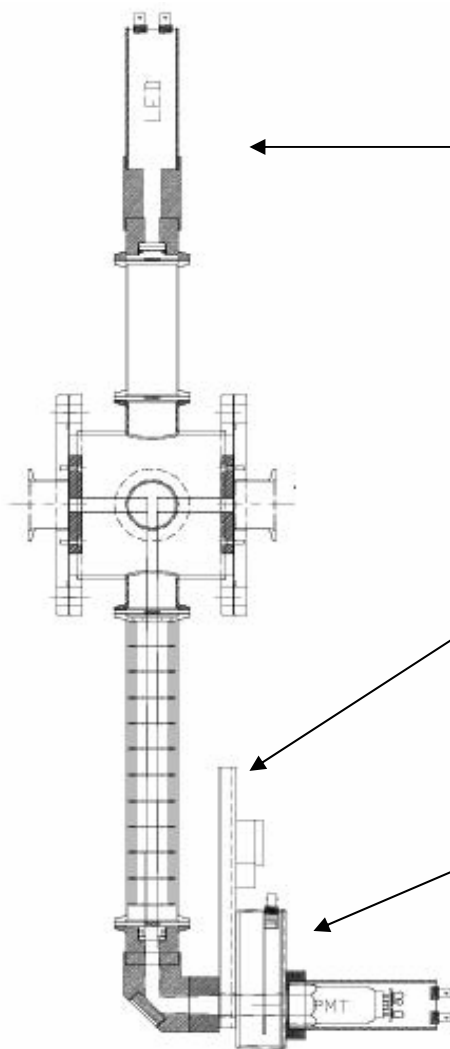

- 2 opposing LED calibration sources.
- 2 remotely controllable filter wheels.
- 8 (4 per PMT) post filter LED calibration sources.
- Two signal PMTs.



# The Main Chamber

$$n_{\phi}(\lambda)$$

X

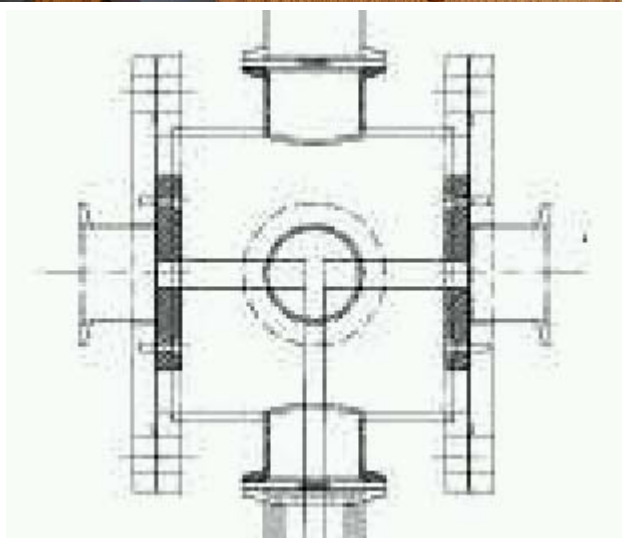

Inside view



# The Main Chamber Detector Unit

LED board

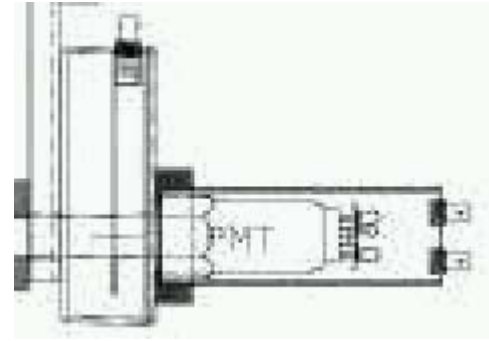
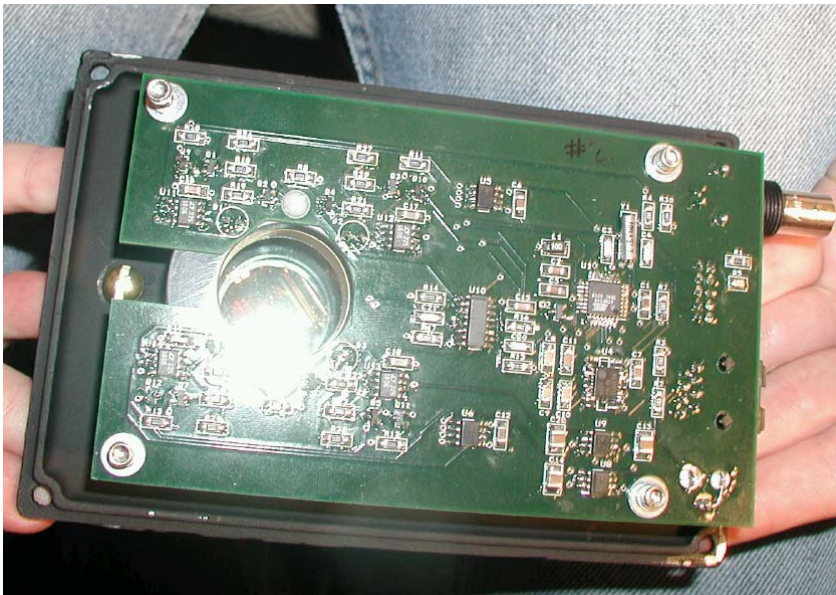

PMT +  
LED box



# The Main Chamber: Detector Unit

$$n_{\phi}(\lambda)$$

PMT +LED box +  
filter wheel holder

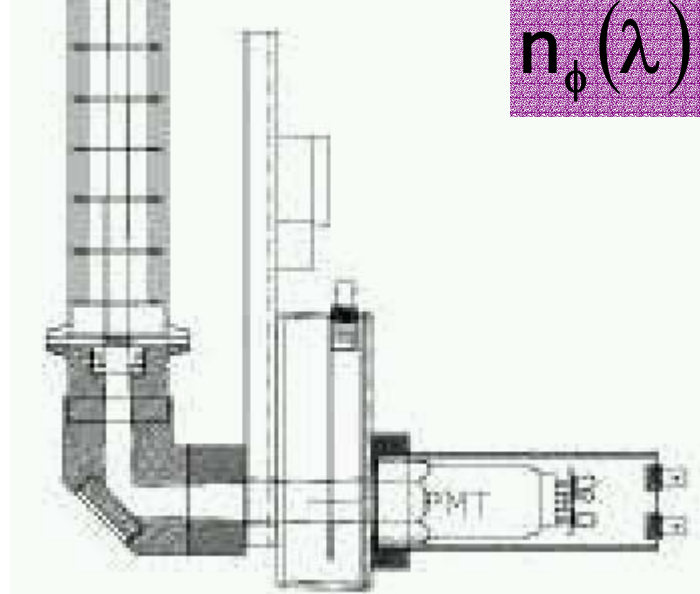

Filter wheel



Mirror unit

$$n_{\phi}(\lambda)$$

# The Main Chamber: Detector Unit

Mirror unit attached to chamber extension

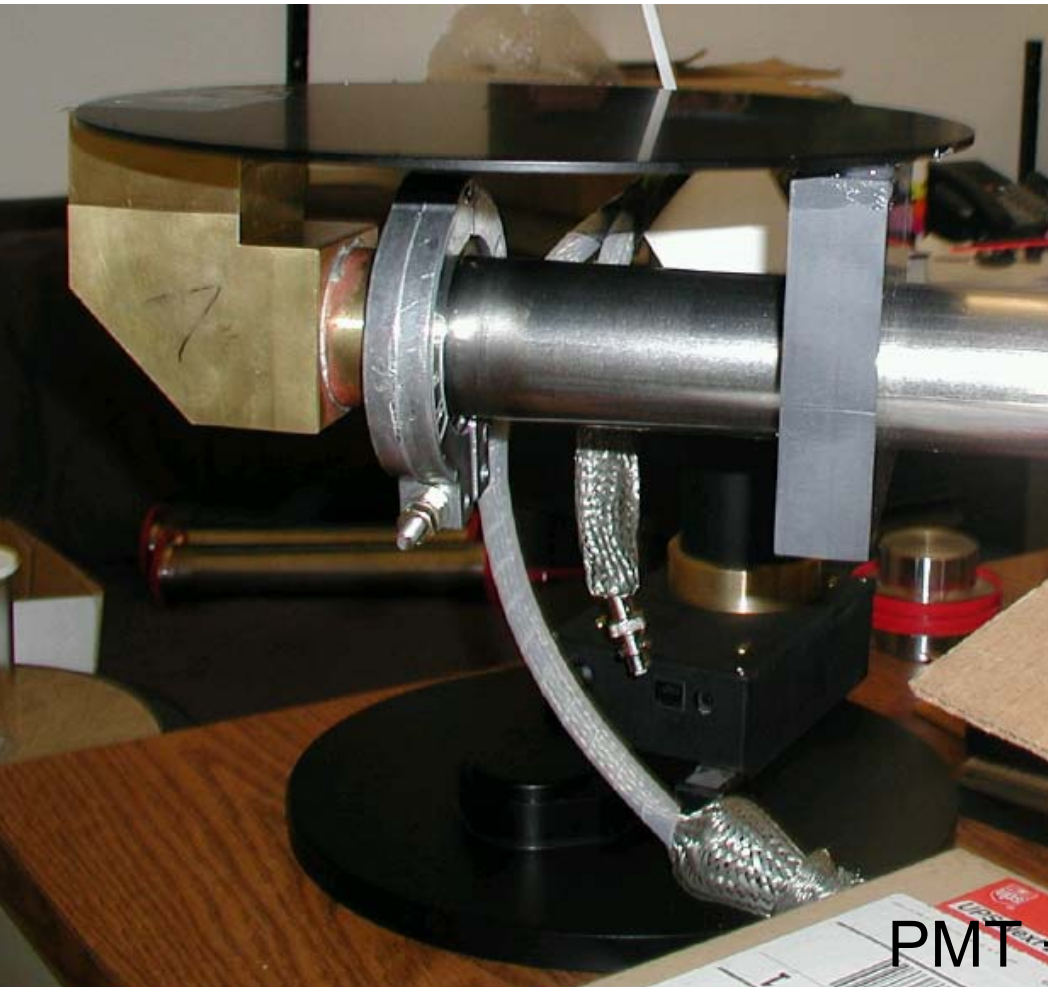

PMT + LED box + filter wheel holder

# The Main Chamber: Detector Unit

## FILTERS

Scans with a spectrophotometer:  
4 filter sets were available and the best 2 in terms of transmission efficiency were selected

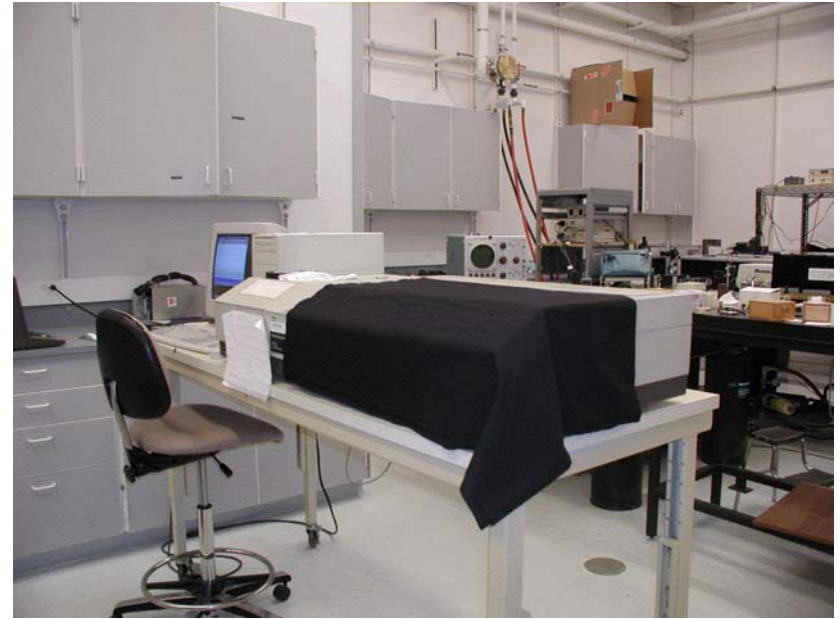

390 nm filters % Transmission vs. Wavelength (nm) all sets

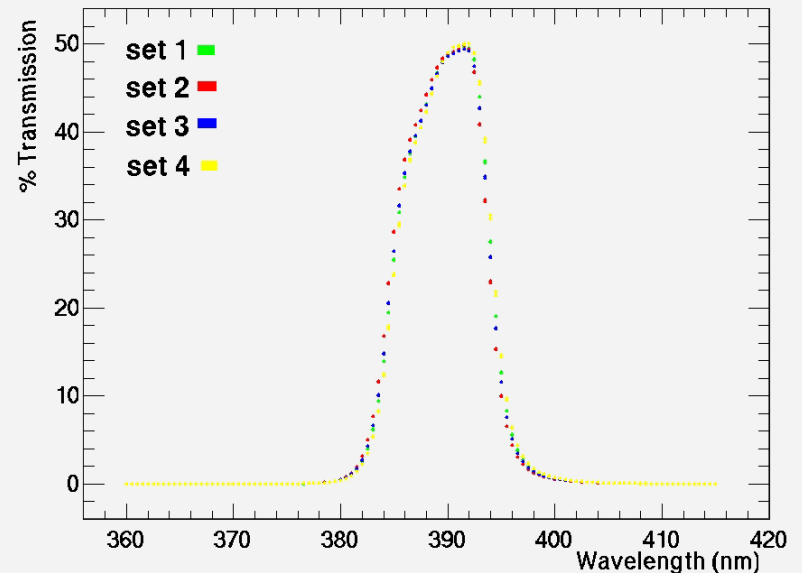

# The Main Chamber: Detector Unit

$$n_{\phi}(\lambda)$$

## FILTERS

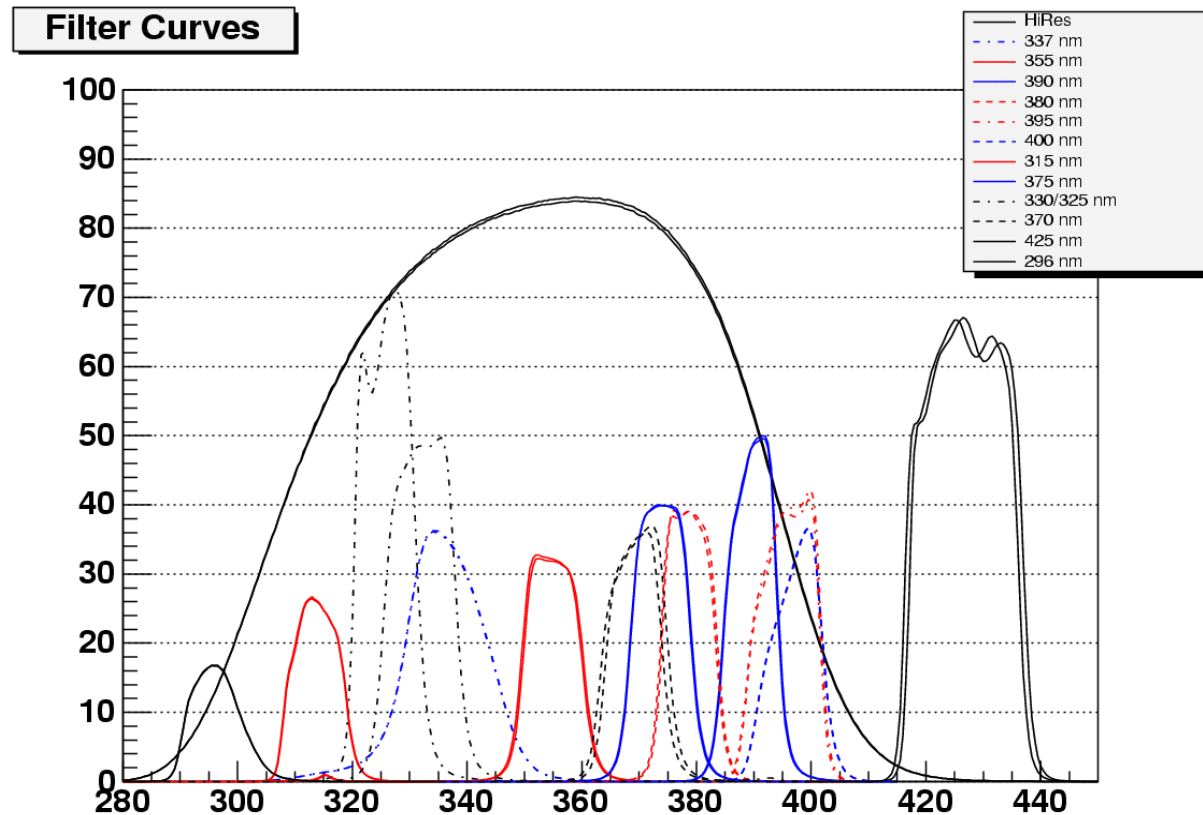

The filters (D355/10X, D425/10X) whose transmissions I had measured before were irradiated by Dr. Kevin Reil at Stanford University and sent back to the University of Utah. Here is the information from Kevin on the irradiation. The source was Co60 which has a rate of 11608 R/h on contact. The filters were placed in contact for 2 hours and 35 minutes. (9:53 to 12:28). Immediately beside the filters was an optochromatic dosimeter (40M white source) which is "pretty accurate" at high doses. Using the optical density reader afterwards the dose given was 32.86 kRad (average of three numbers which I do not know). Approx. 5 minutes afterwards the filters were repackaged in the original packing and placed in a cooler full of dry ice.

# The Main Chamber: Detector Unit

## FILTERS

Radiation tests: Two filters,  
355 nm and 425 nm, were  
irradiated at SLAC

- source Co60
- 32.86 kRad

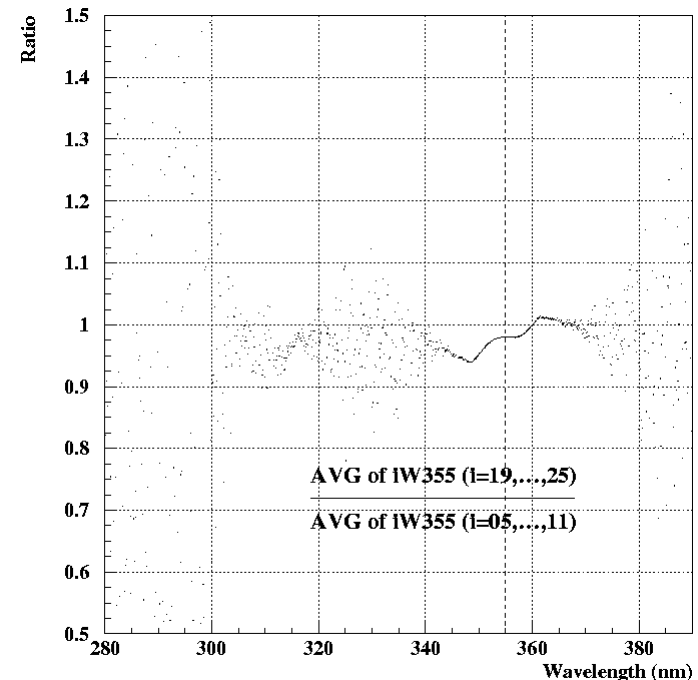
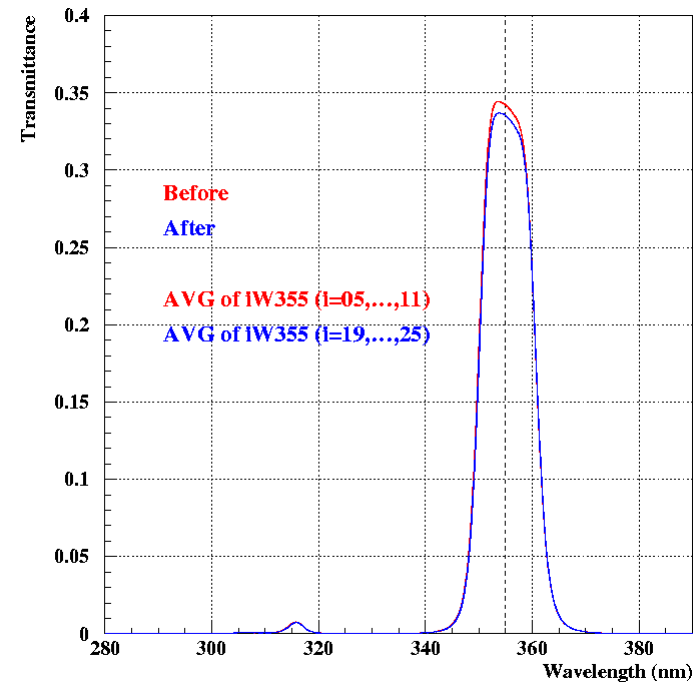

$$n_{\phi}(\lambda)$$

# The Main Chamber: Detector Unit

## FILTERS

Radiation tests: 425 nm

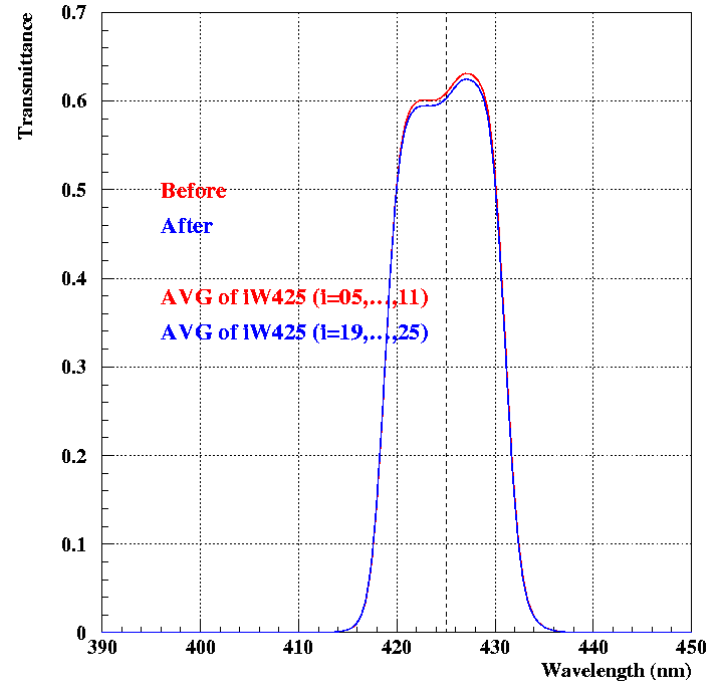

$$n_{\phi}(\lambda)$$

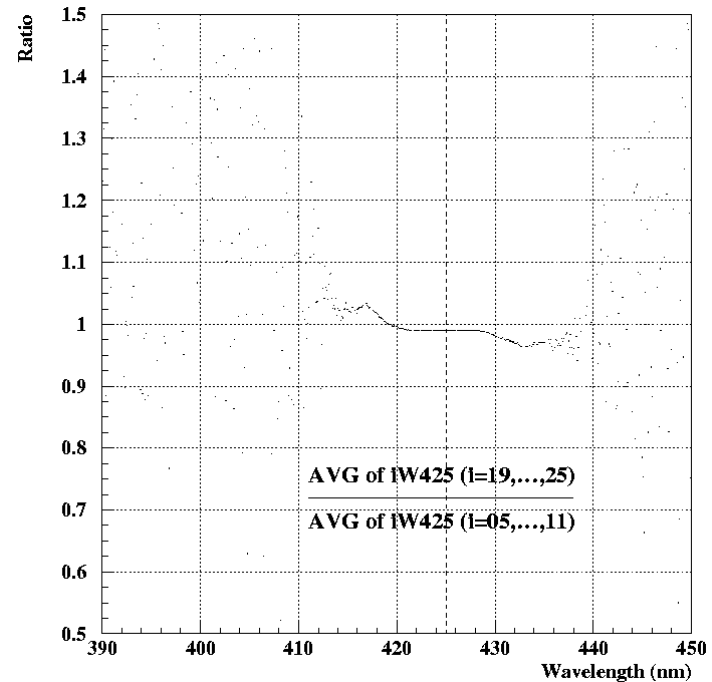

# The Main Chamber: Detector Unit

$$n_{\phi}(\lambda)$$

Filter scans were used as input for a simulation to estimate the signal size before the run

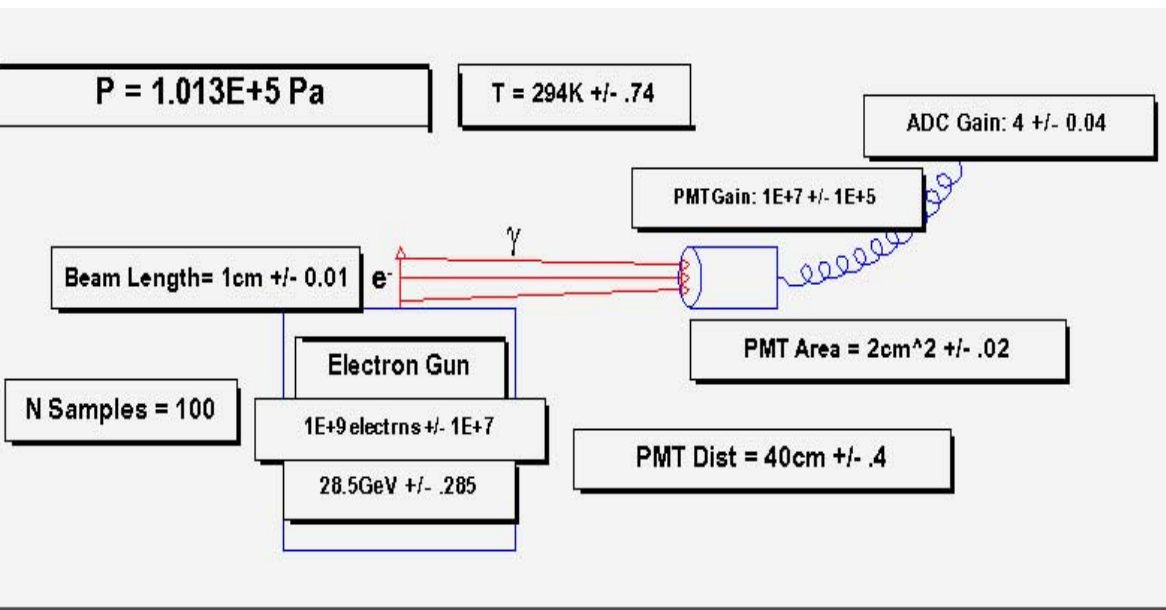

+

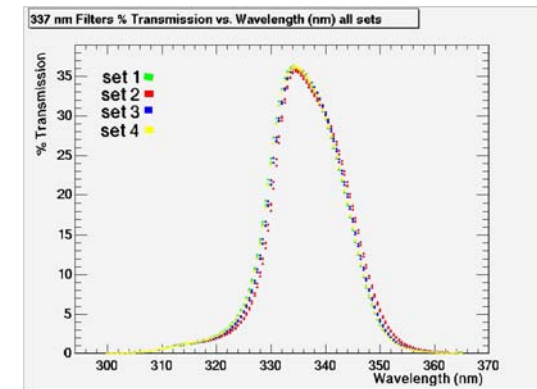

and other  
assumptions

# The Main Chamber: Detector Unit

## Filter wheel assembly

Filter Wheel A .....		Filter Wheel B .....	
Position	Filter	Position	Filter
0		0	
1	Black	1	Black
2	Open	2	Open
3	HiRes Glass (HR_1)	3	HiRes Glass (HR_4)
4	D337_10_1	4	D337_10_4
5	D355_10_1	5	D355_10_4
6	D390_10_1	6	D390_10_4
7	D380_10_1	7	D380_10_4
8	D395_10_1	8	D395_10_4
9	D400_10_1	9	D400_10_4
10	D315_10_1	10	D315_10_4
11	D375_10_1	11	D375_10_4
12	D330_10_1	12	D325_10_4
13	D370_10_1	13	D370_10_4
14	D425_20_1	14	D425_20_4
15	D296_10_1	15	D296_10_4

ADC Range: ~60 - 6000  
P.E. Range: ~12 - 1200

Central Wavelength

Width

# The Main Chamber: Detector Unit

$$n_{\phi}(\lambda)$$

A little more detail about the previous simulation

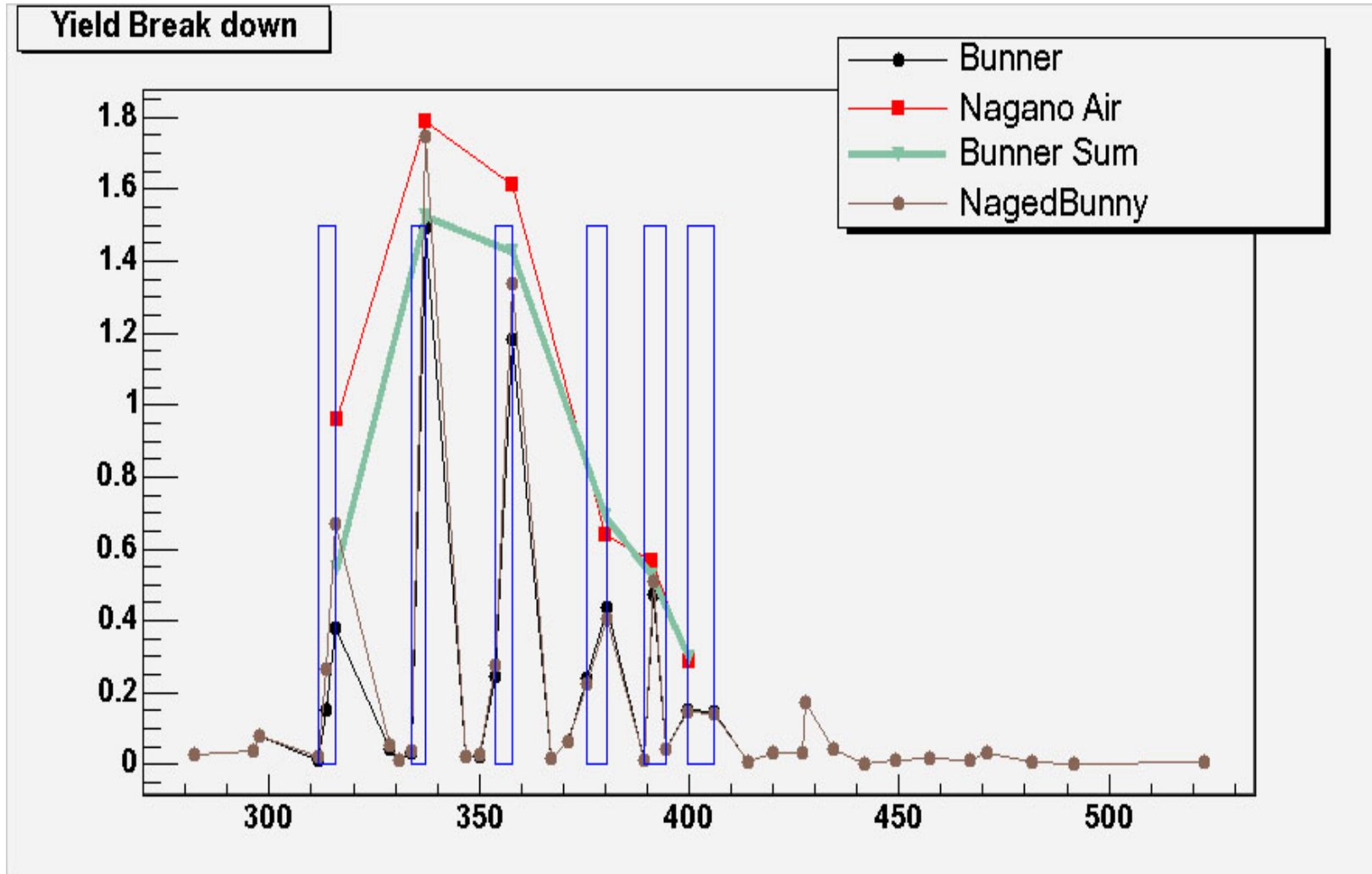

# THE MAIN CHAMBER

During the run

# The Main Chamber: Detector Stability Monitoring

HV North PMT

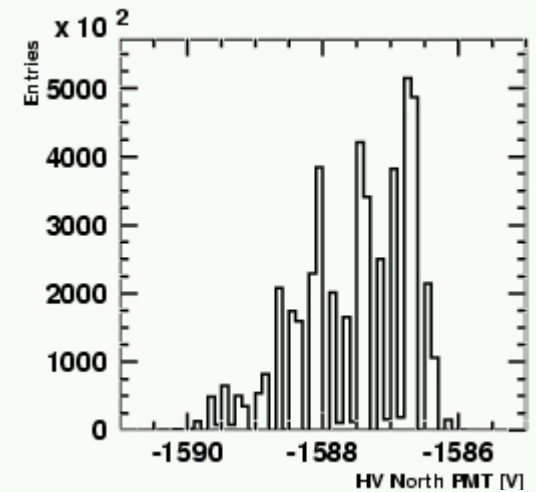
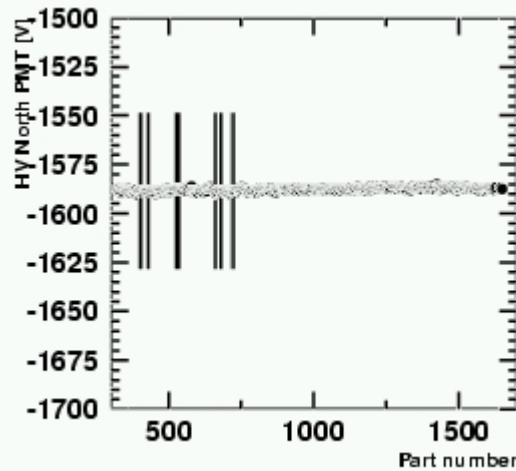

HV South PMT

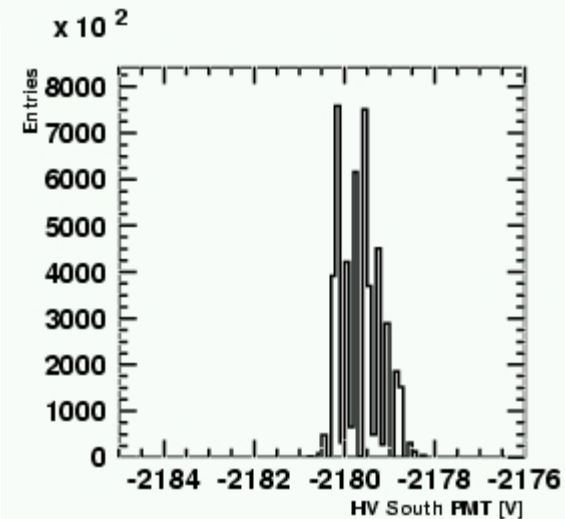
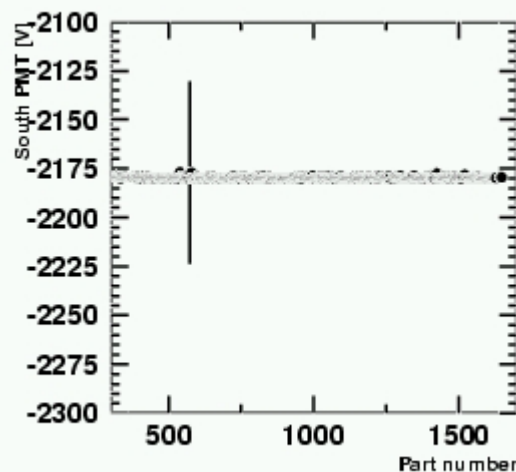

# The Main Chamber: Detector Stability Monitoring

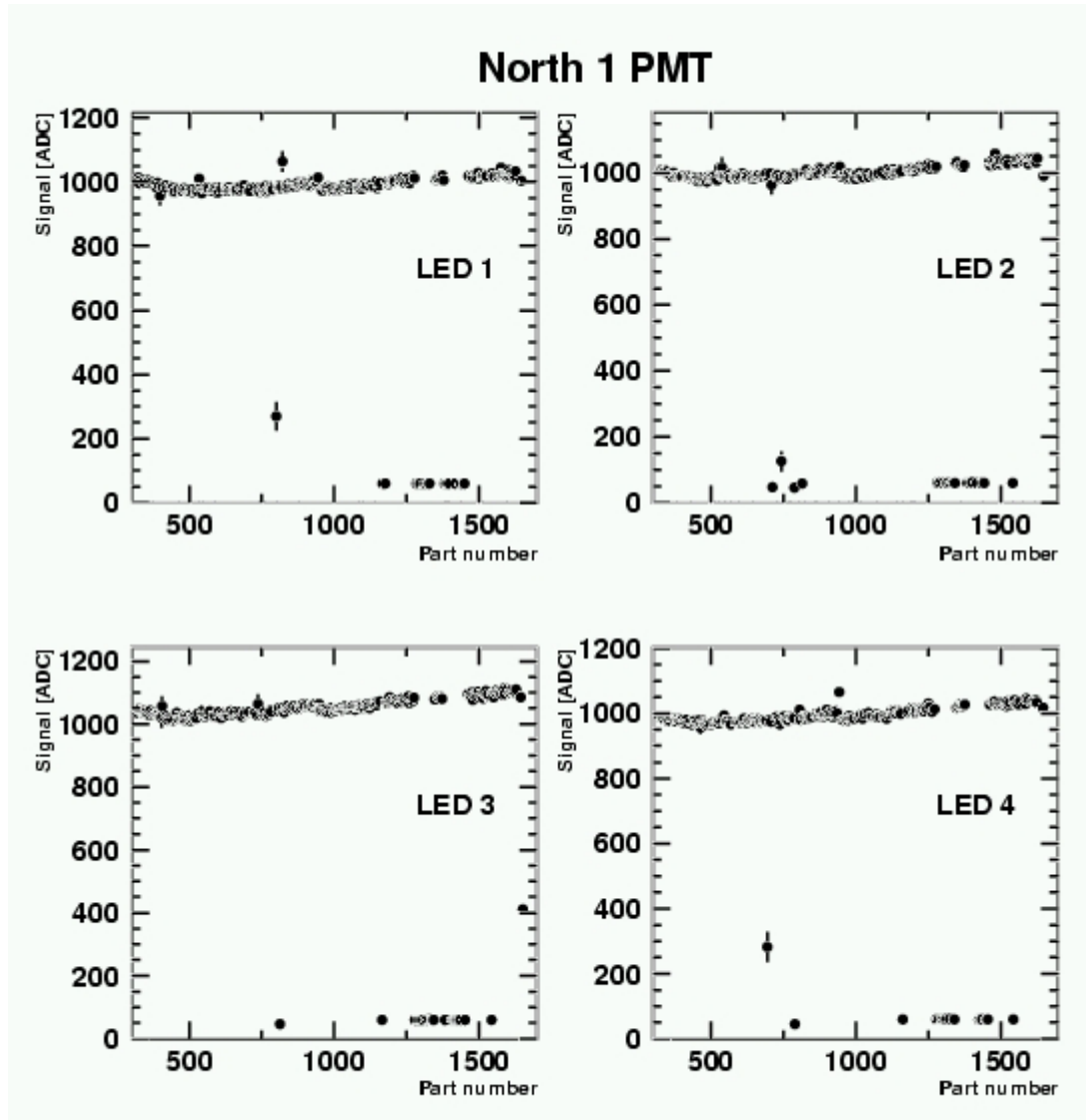

# The Main Chamber: Detector Stability Monitoring

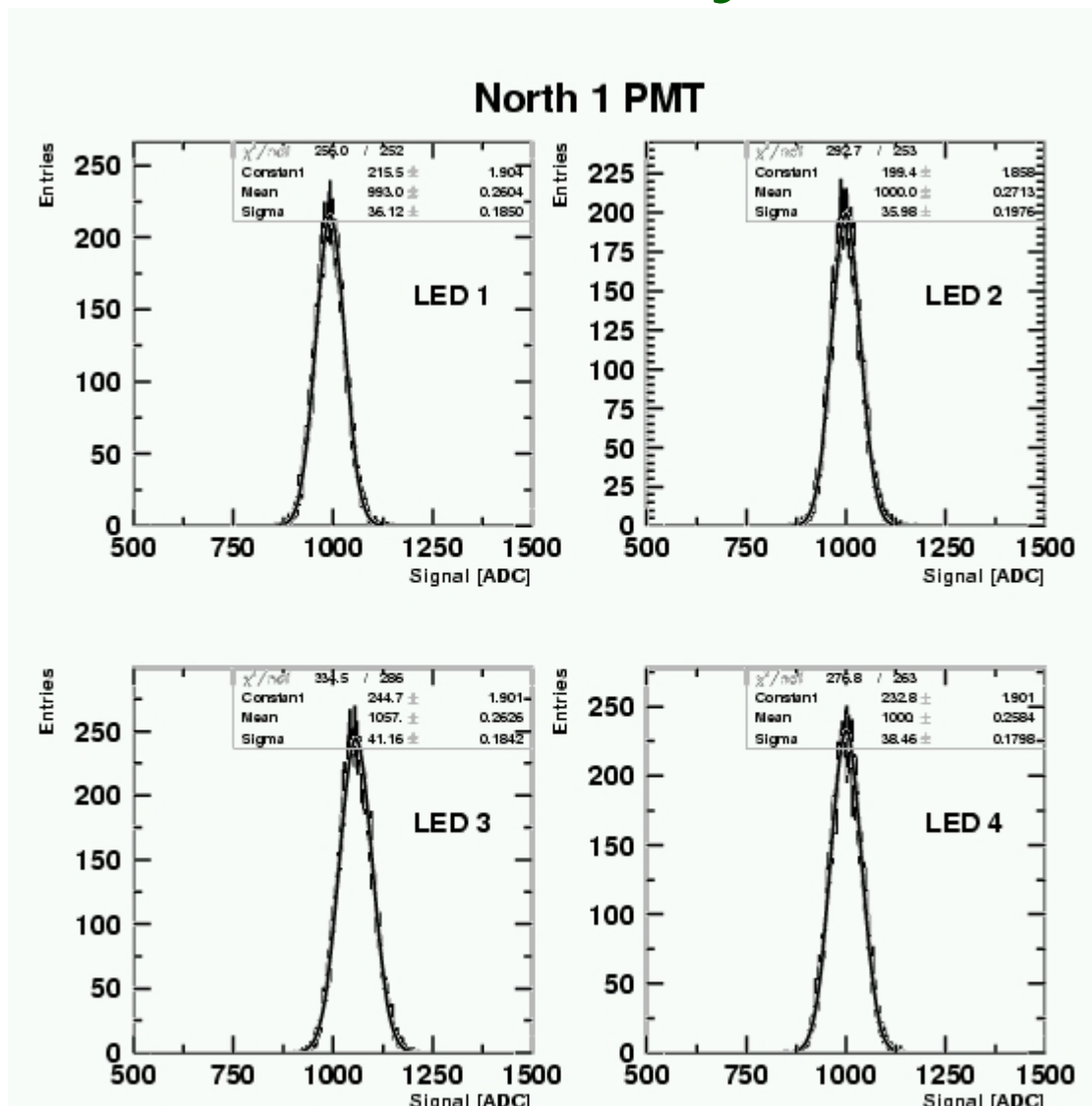

# The Main Chamber: Detector Stability Monitoring

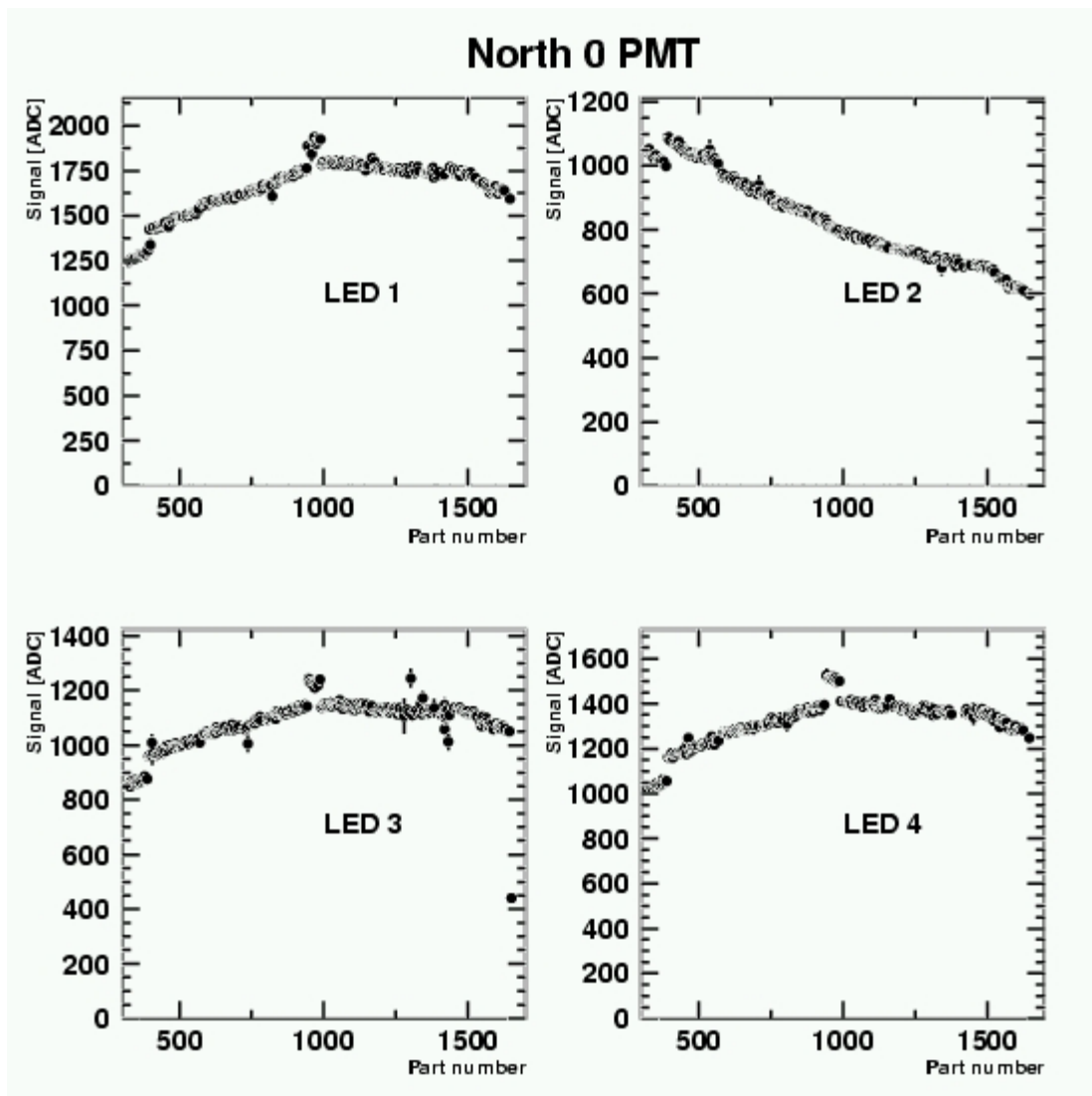

# THE MAIN CHAMBER

After the run

# The Main Chamber: Calibration - 3 Steps

1. Transfer PMT response SLAC - Utah:
  - LED response comparison to monitor possible gain changes
  - at SLAC: temperature monitoring

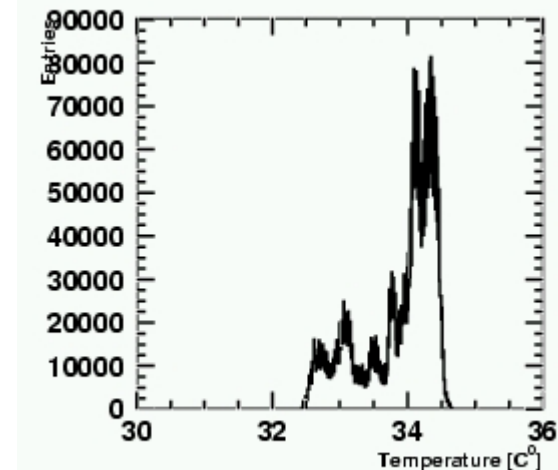
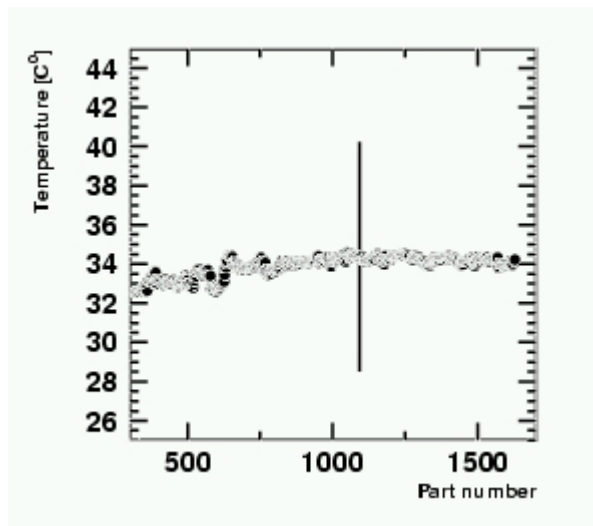

# The Main Chamber: After the run Calibration - 3 Steps

1. Transfer  
PMT response  
SLAC - Utah:

- first studies of the  
temperature dependence  
in Utah

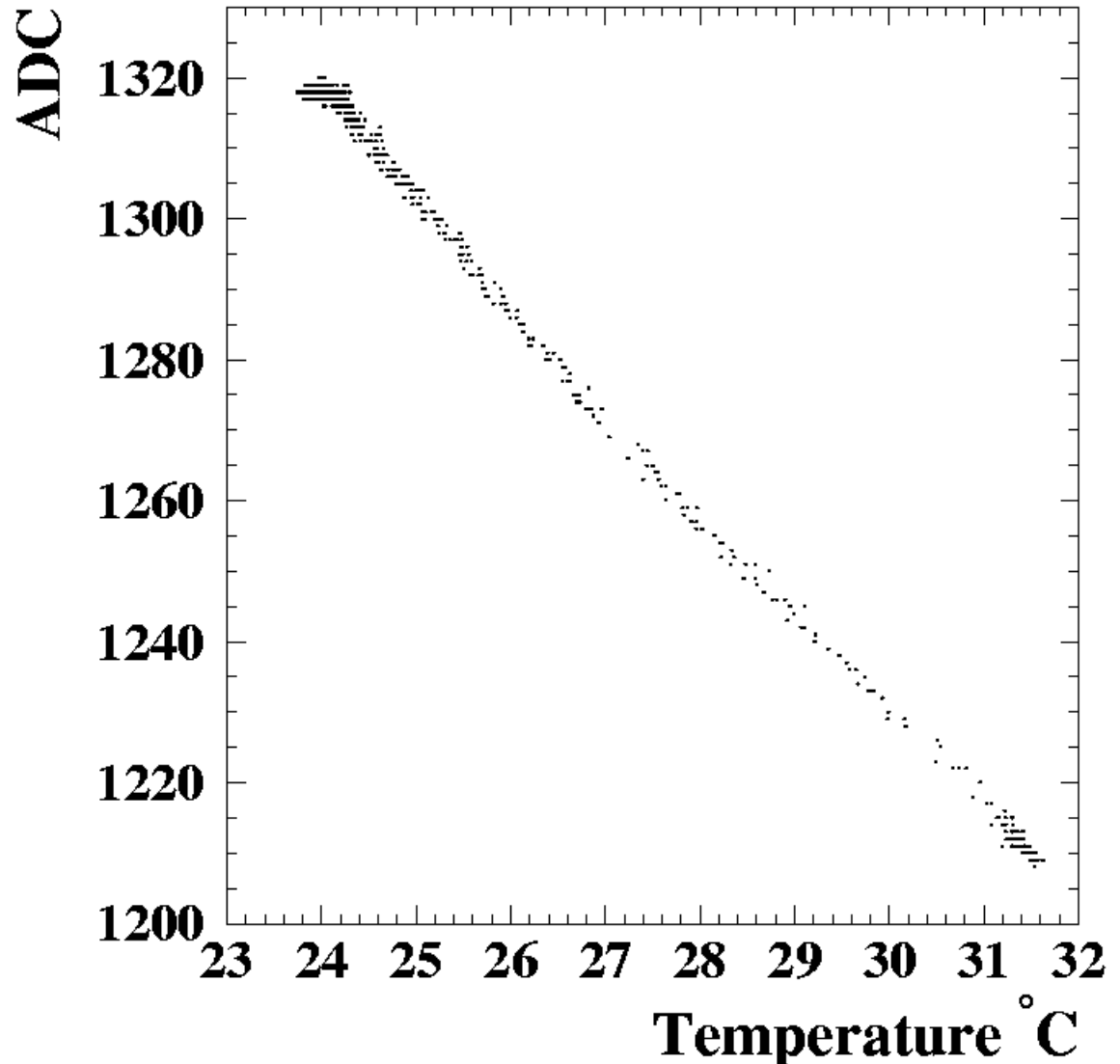

# The Main Chamber: Calibration - 3 Steps (cont.)

## 1. Transfer PMT response SLAC - Utah:

- at Utah: insulated housing around whole setup

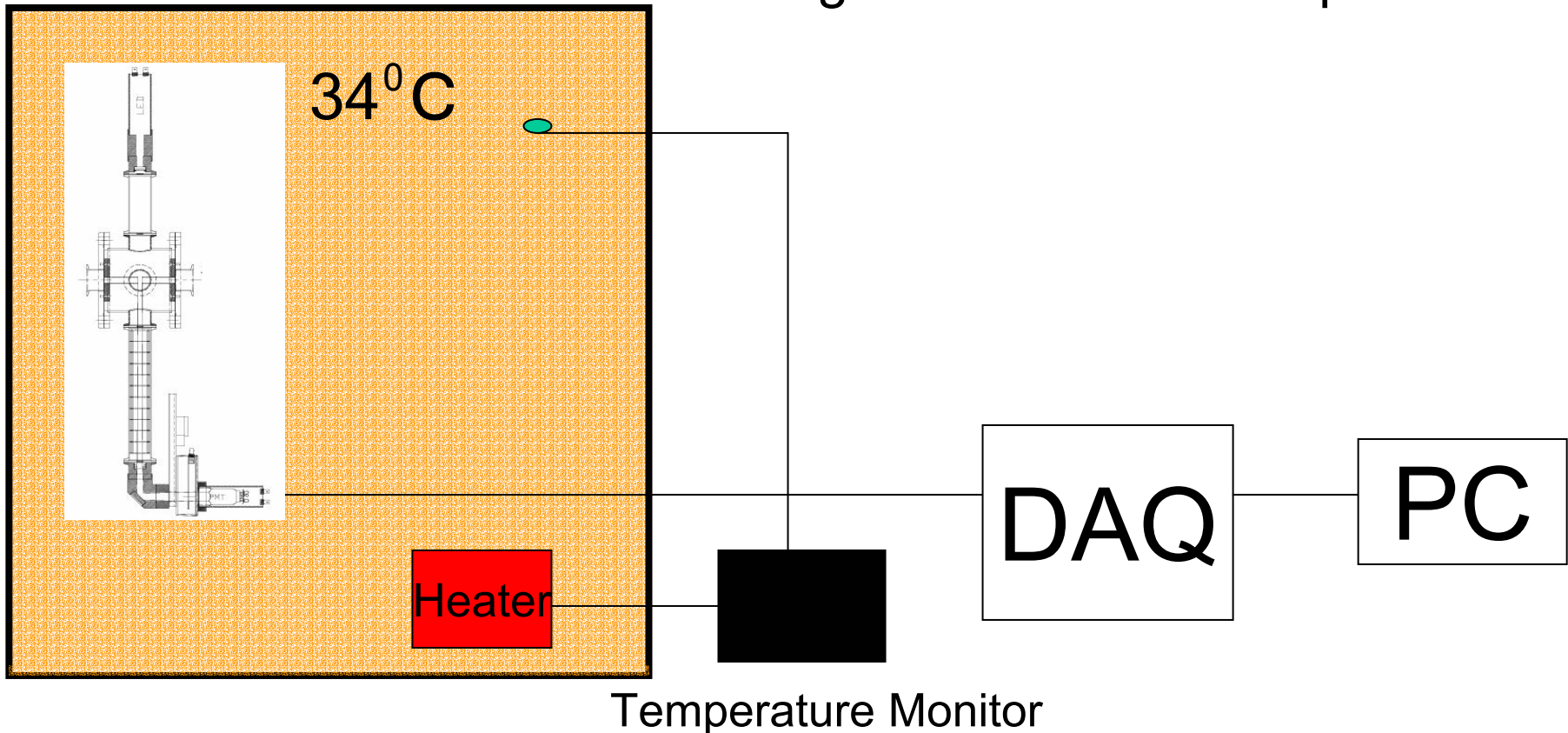

# The Main Chamber: Calibration - 3 Steps (cont.)

$$n_{\phi}(\lambda)$$

X

## 2. End-to-end calibration: Rayleigh Scattering

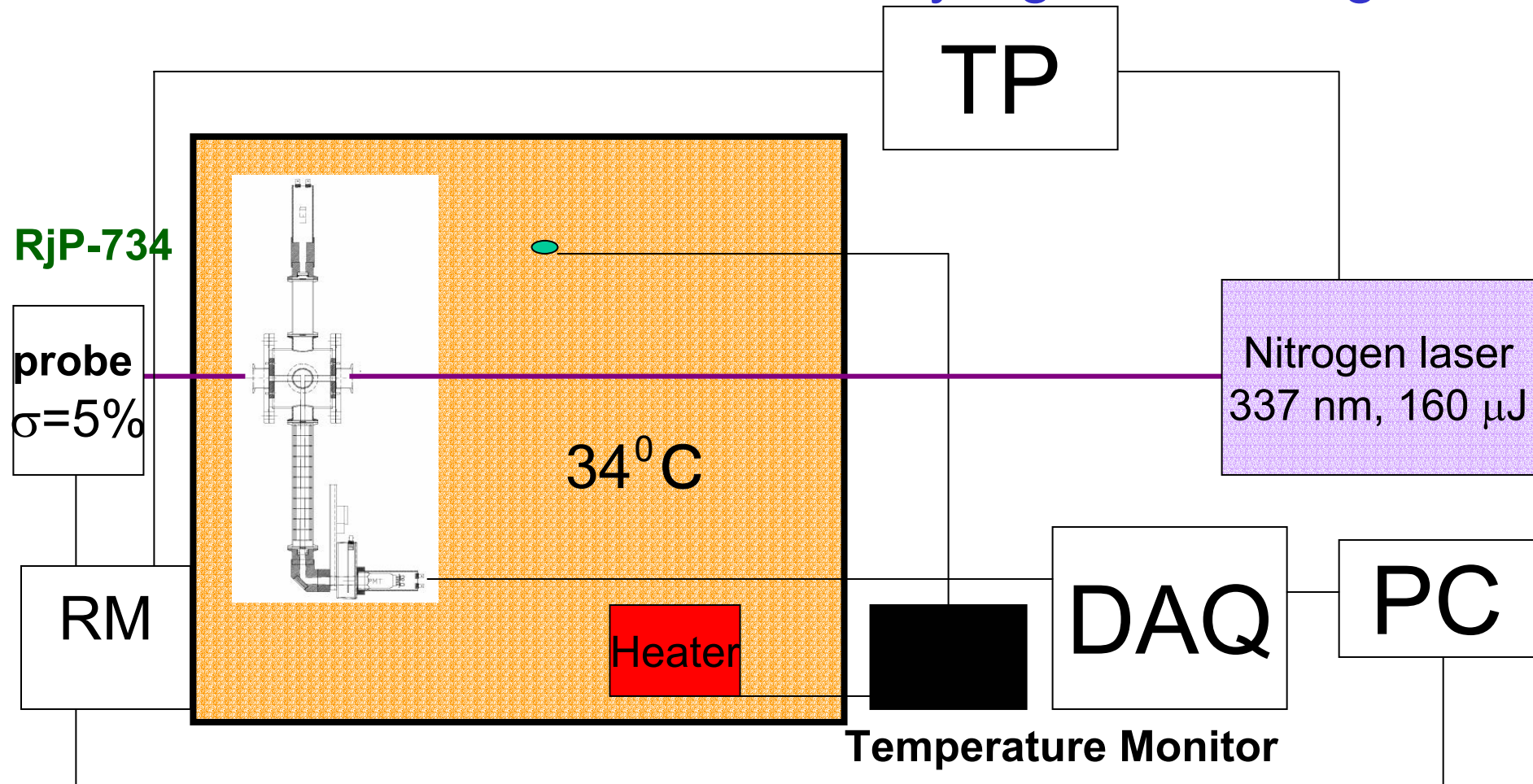

# The Main Chamber: Calibration - 3 Steps (cont.)

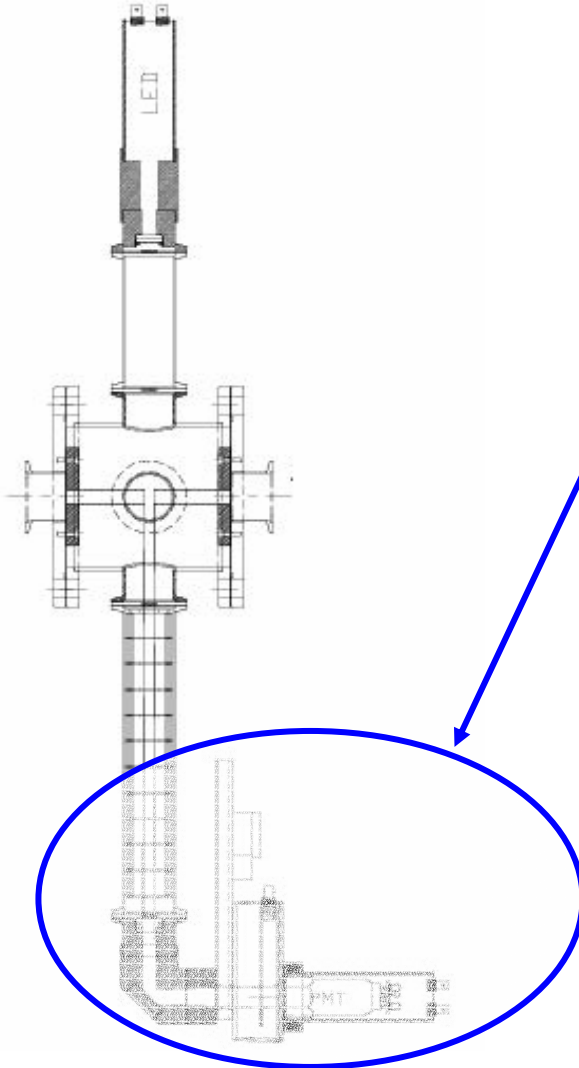

3. Detector unit:  
absolute calibration

# The Main Chamber: Calibration - 3 Steps (cont.)

## 3. Detector unit: absolute calibration

### set up

- Focal length:** 130nm, F/3.7
- Accuracy :** 0.50nm
- Precision :** 0.11nm
- Stray light :** 0.03%
- Scan speed :** 350nm/s

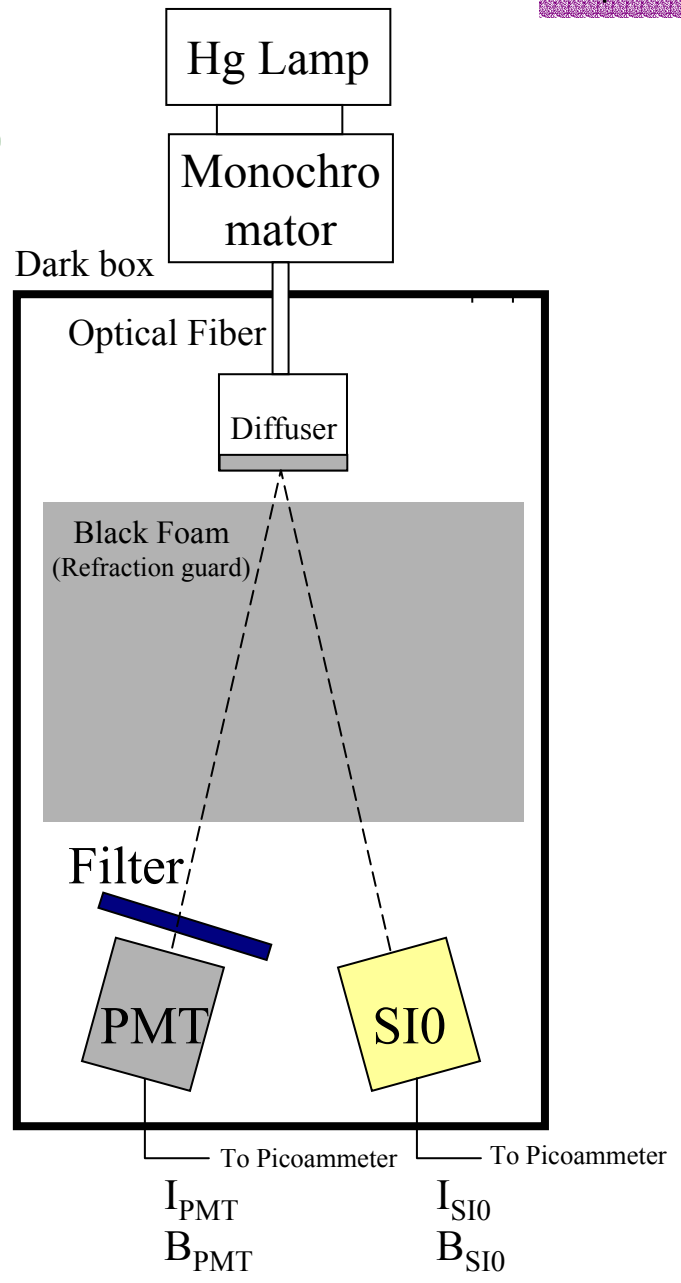

# The Main Chamber: Calibration - 3 Steps (cont.)

$$n_{\phi}(\lambda)$$

## 3. Detector unit: absolute calibration

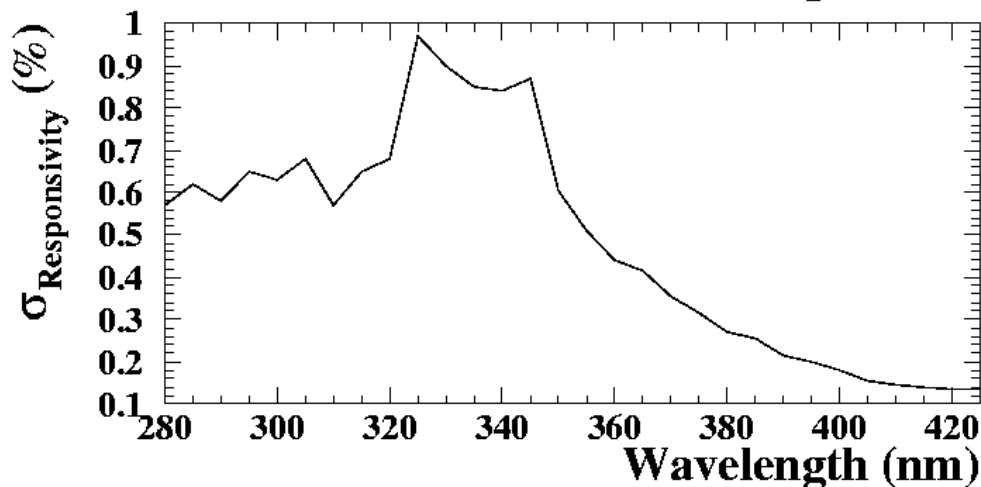
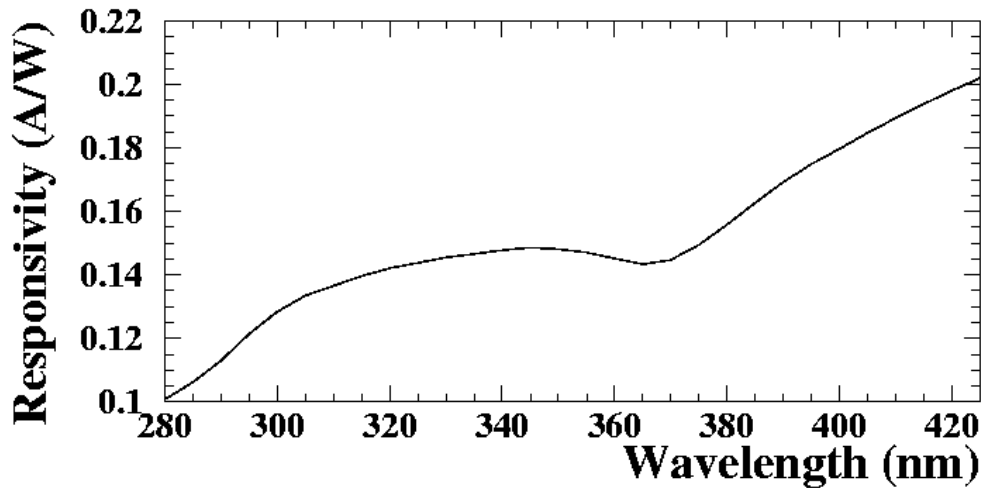

The NIST calibrated  
SI photodiode



# The Main Chamber: Calibration - 3 Steps (cont.)

$$n_{\phi}(\lambda)$$

## 3. Detector unit: absolute calibration

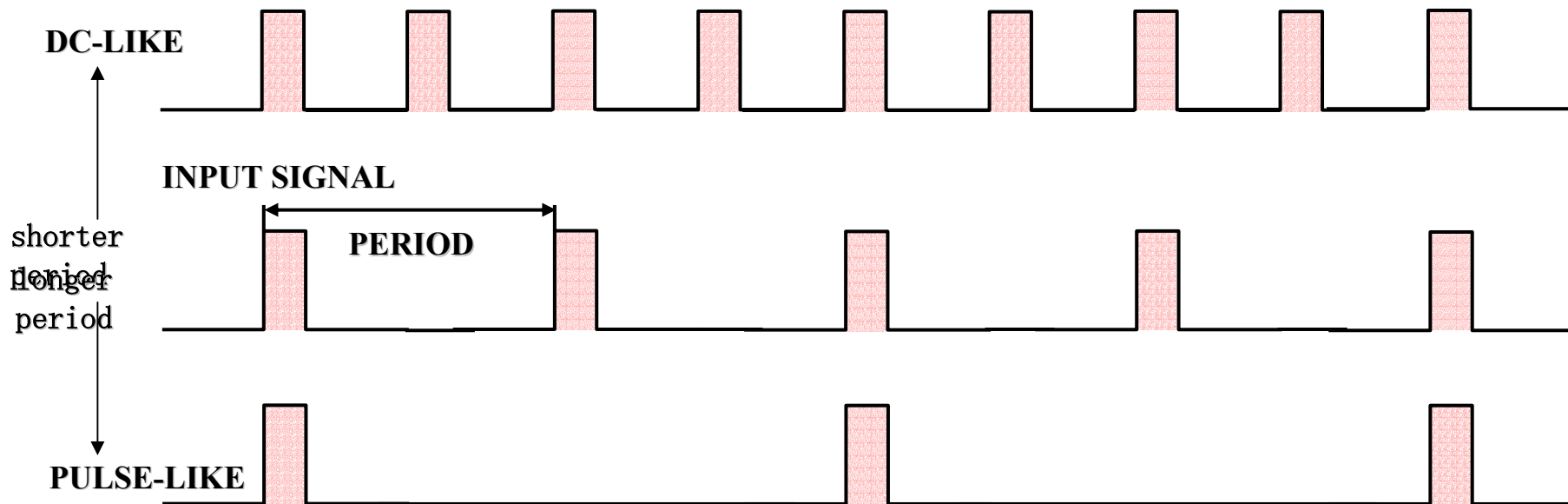

Compatibility of  
DC and pulsed  
light measurements

Measuring the  
pulse area

# The Main Chamber: Calibration - 3 Steps (cont.)

$$n_{\phi}(\lambda)$$

## 3. Detector unit: absolute calibration

**Pulse generator**  
CH1: Input to LED  
CH2: Trigger for Oscilloscope

**PMT**  
Reduced photon-sensitive area  
2 HiRes Filters

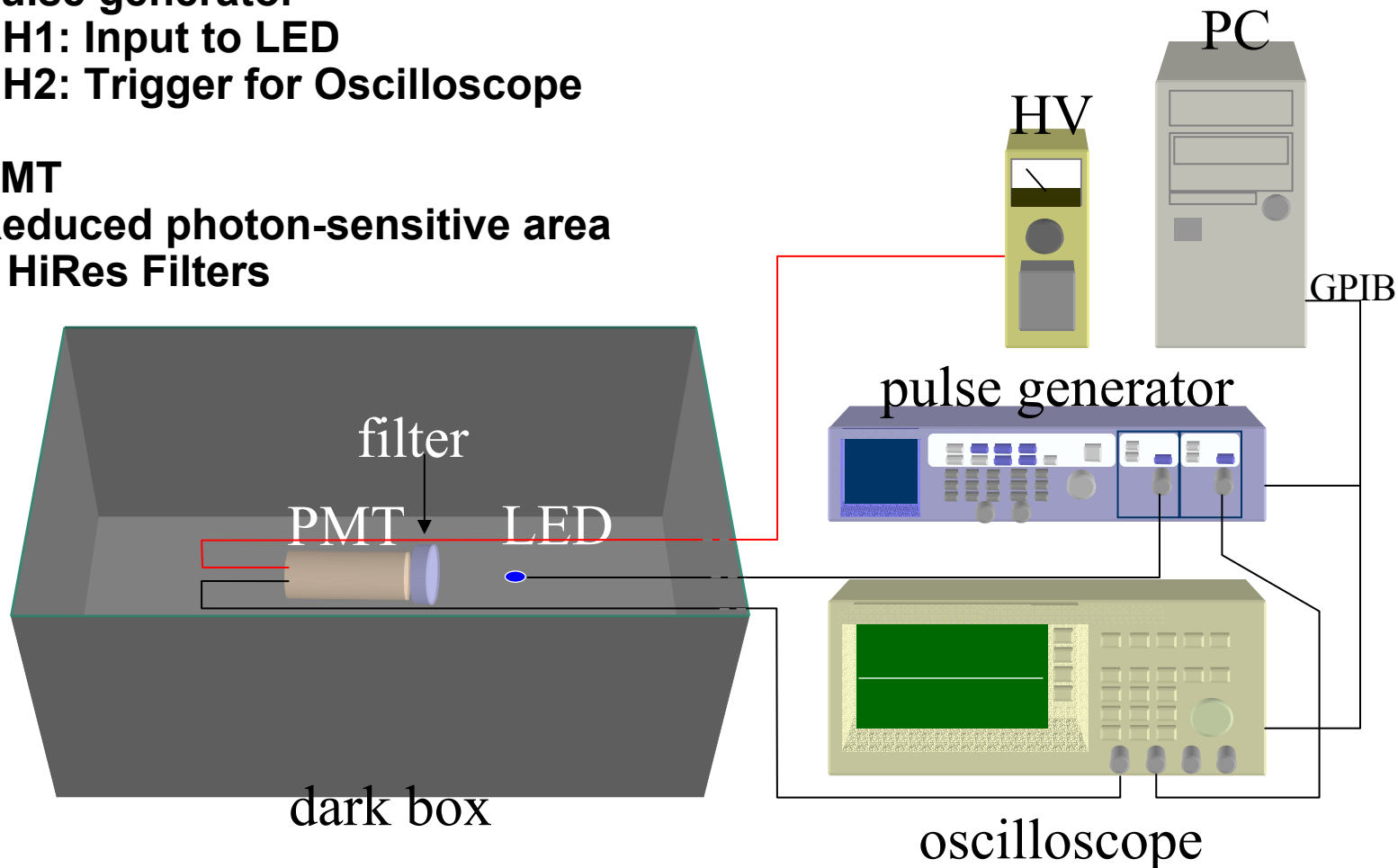

# The Main Chamber: Calibration - 3 Steps (cont.)

$$n_{\phi}(\lambda)$$

## 3. Detector unit: absolute calibration

### Result 1

Light source	<b>Blue LED</b>
Pulse	<b>200ns</b>
Current	<b>16mA</b>

- Tested period
  - 100ms, 30ms, 10ms, 3ms, 1ms,
  - 300us, 100us, 30us, 10us, 3us
- Pulse area normalized @3us >>> Fig.1
- Fluctuation less than 2%

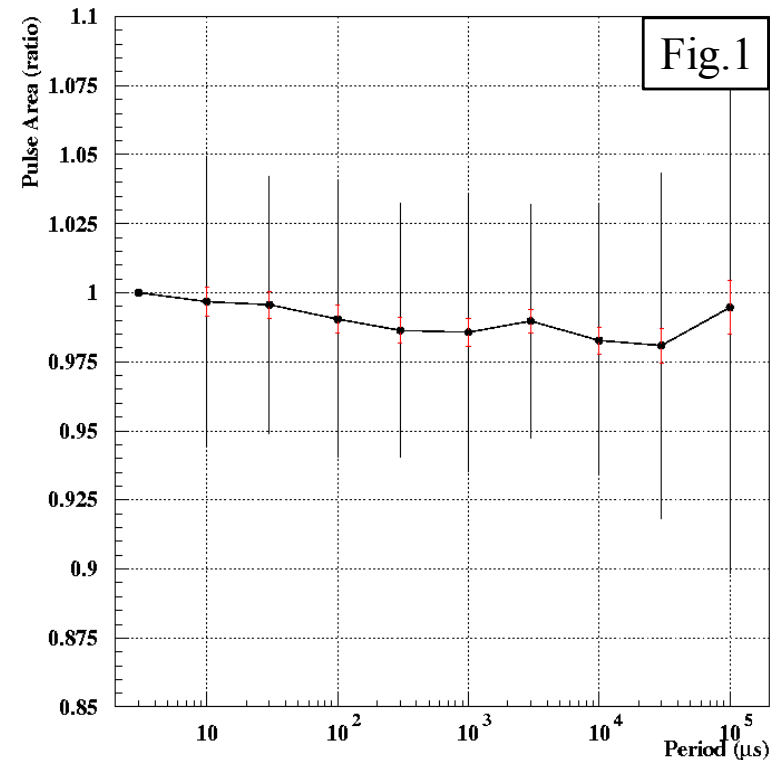

# The Beam Charge Measurement

# E-165 Toroid

- E-165 is an atypical beam user. Requests for reduced beam intensity not common.
- Existing beam feedback was not designed for our required  $10^9$  or less  $e^-$  per pulse.
- A low beam charge toroid was designed and implemented for our run.
- Two gain modes.

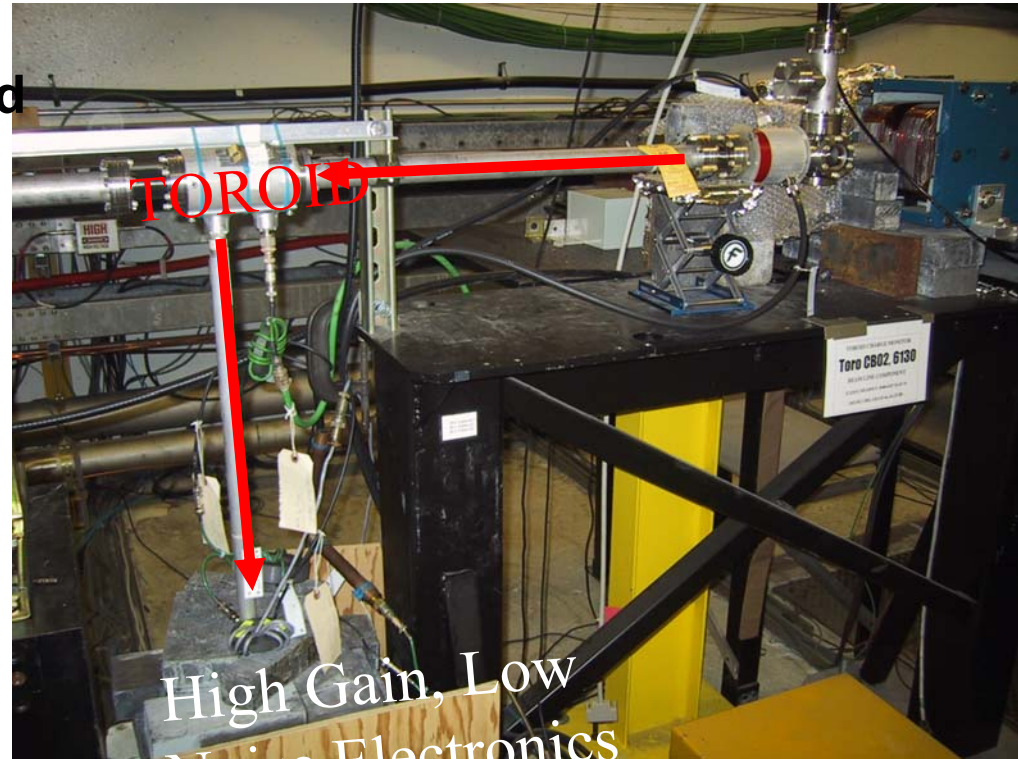

# Beam Charge Measurement

$n_{e^-}$

- **Specs:**
- **Sensitivity Range: 1E7 – 1E9 elec.**
- **Accuracy: 1%**
- **Calibrations via charge inj.:**
  - electronics only
  - toroid + electronics
- **Noise Achieved**  
in lab: 1.5E5 elec.

The unit

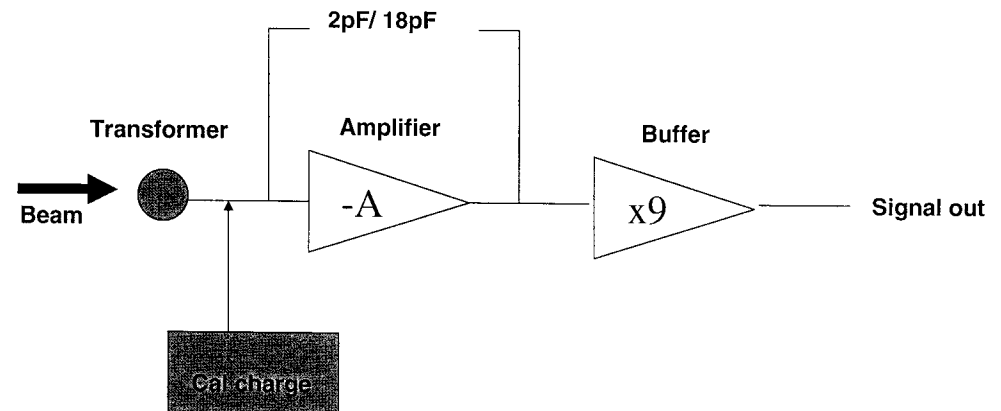

# Beam Charge Measurement

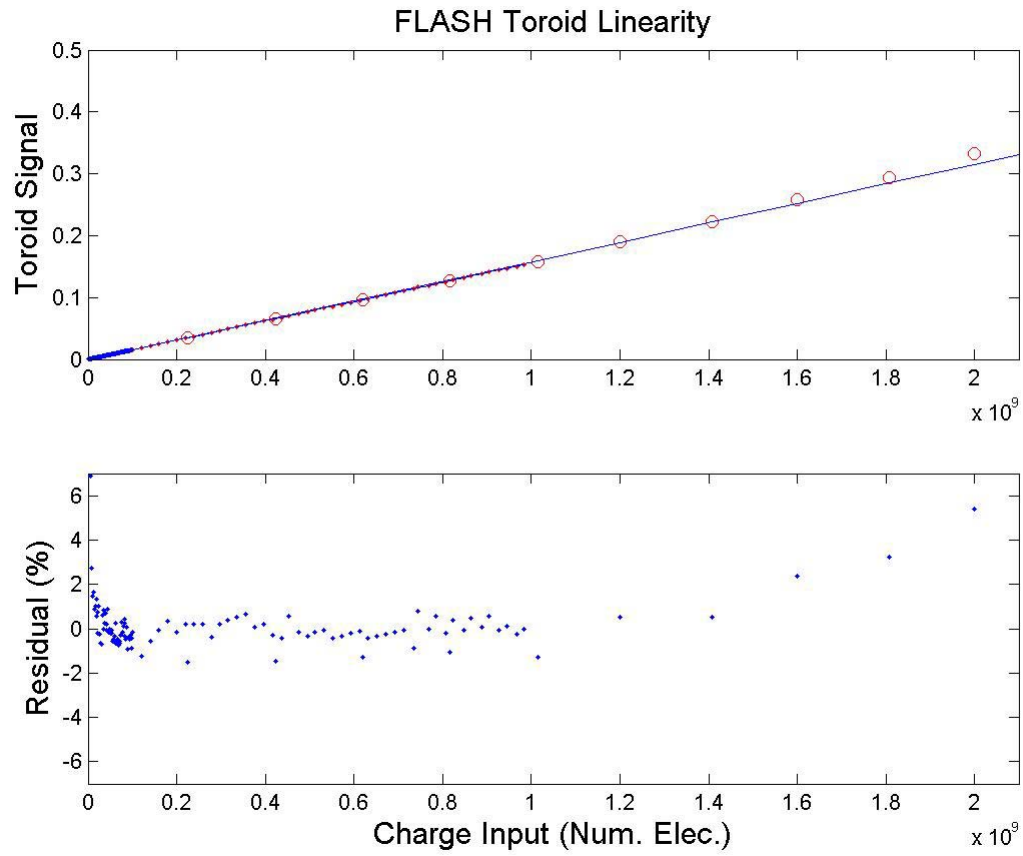

# Beam Charge Measurement

## Non-Linearity

- Photons/e<sup>-</sup> should be constant.
- Non linear effects at high beam intensity were seen in T-461.
- Run near upper end on linear regime.
- All results presented cut beam charge to be within 1.4 to 1.6 billion (1.5E9) electrons per pulse.

North Signal vs Q, HiRes, Air, 750 torr, Run 953

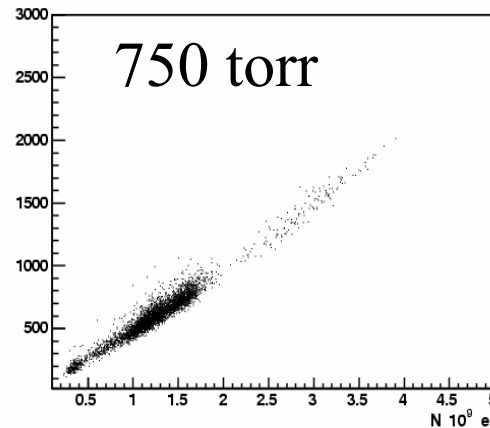

North Signal vs Q, HiRes, Air, 750 torr, Run 953

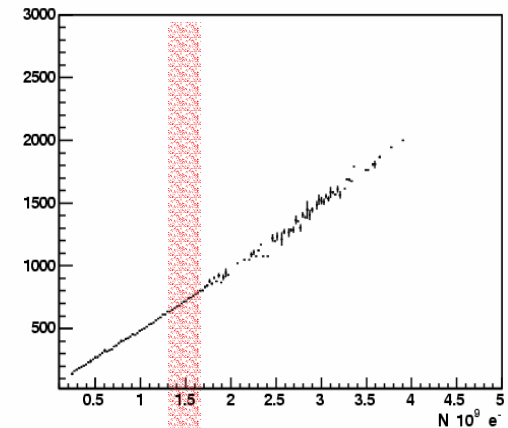

North Signal vs Q, HiRes, Air, 50 torr, Runs 1461-1484

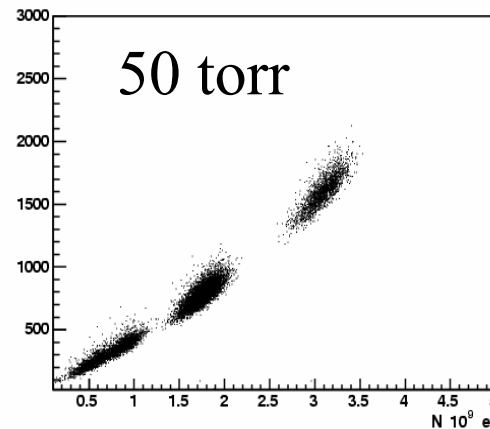

North Signal vs Q, HiRes, Air, 50 torr, Runs 1461-1484

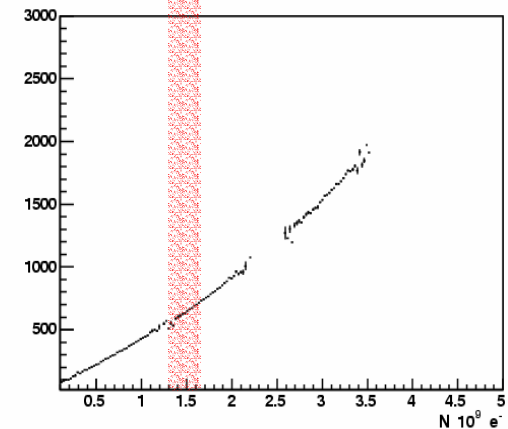

# Other cross checks

- Ray tracing Monte Carlo
- Comparison of E165 and T461 total yield measurement (we used a different chamber, different detector units etc.)
- Comparison of results obtained with main chamber and spectrograph
- use beam spot information for quality cuts, correlation with beam drop outs etc.

# SYSTEMATIC UNCERTAINTIES (as in E165 Proposal)

	Thin Target	Thick Target
Beam	2%	2.2%
Showering	-	3%
Detector System	5.4%	5.4%
Optical System	4%	6.5%
<b>Total</b>	<b>7%</b>	<b>9.2%</b>

# Outlook

- Calibration of the E165 chamber-filter wheel experiment is currently being done at Utah
- We want to complete calibration early next year ( ~ March)
- Goal:  $\sigma = 7\%$
- Cross checking E165 NB filter results with spectrograph results and with the total yield resulting from T461 will be very useful