

# Beam monitoring

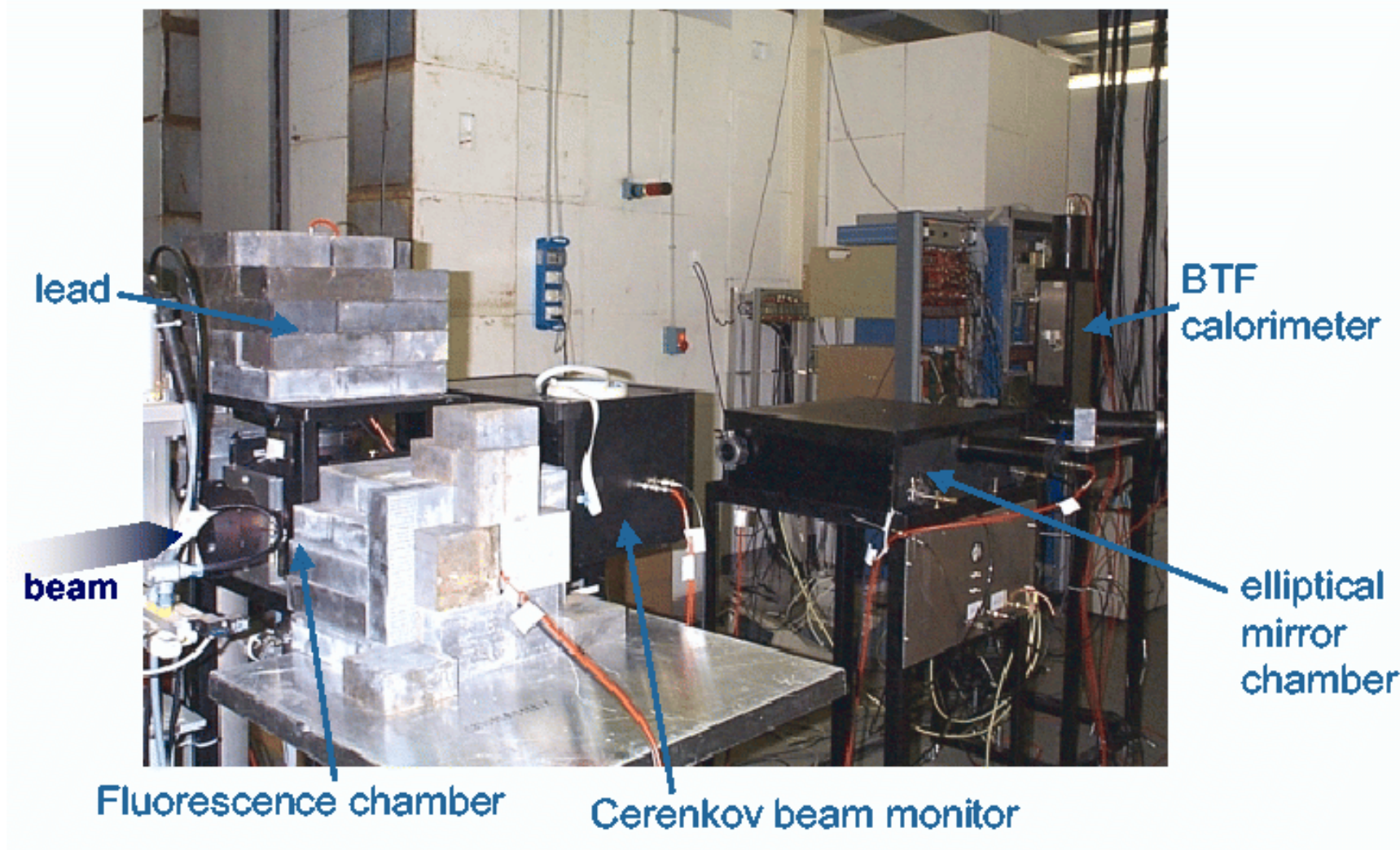

# Calorimeter

lead / scintillating fibers  
 low multiplicity (1-1000 e<sup>-</sup>)  
 resolution 4.7%/√E(GeV)

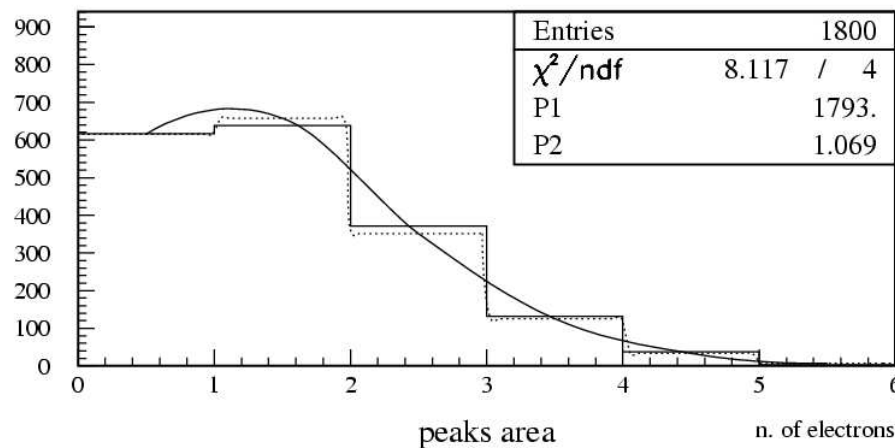
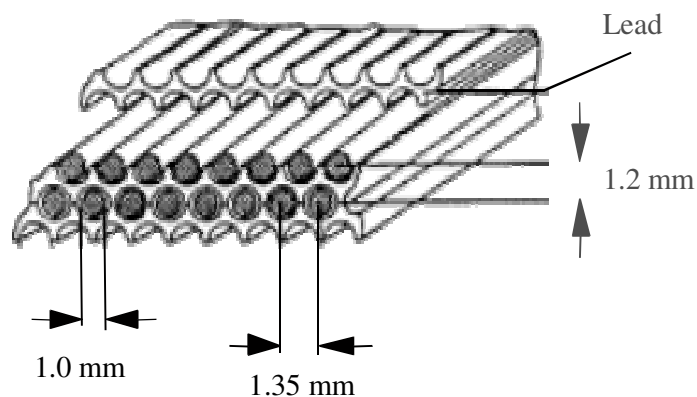
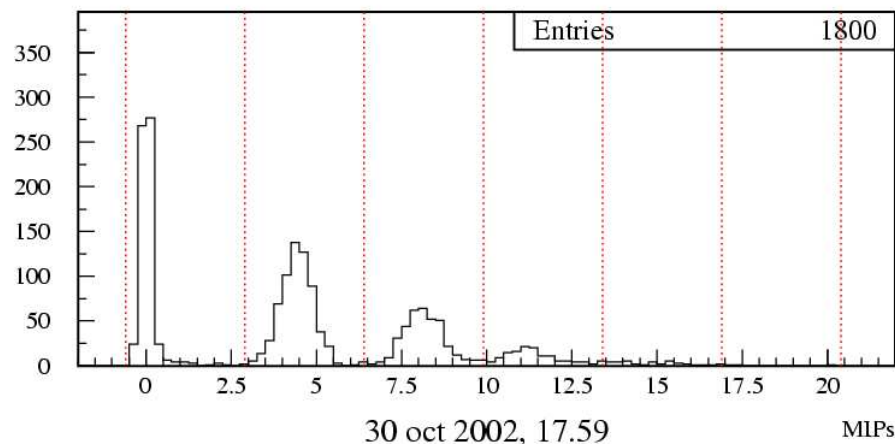

# Calorimeter

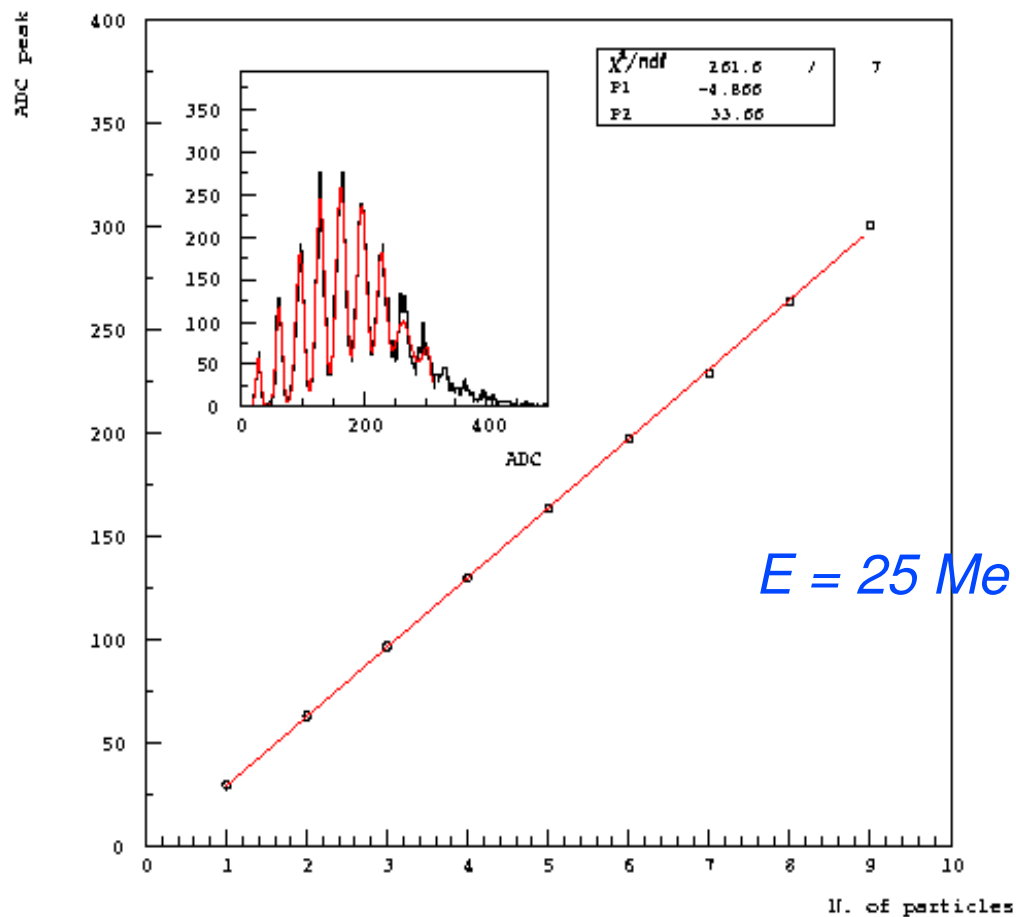

linearity

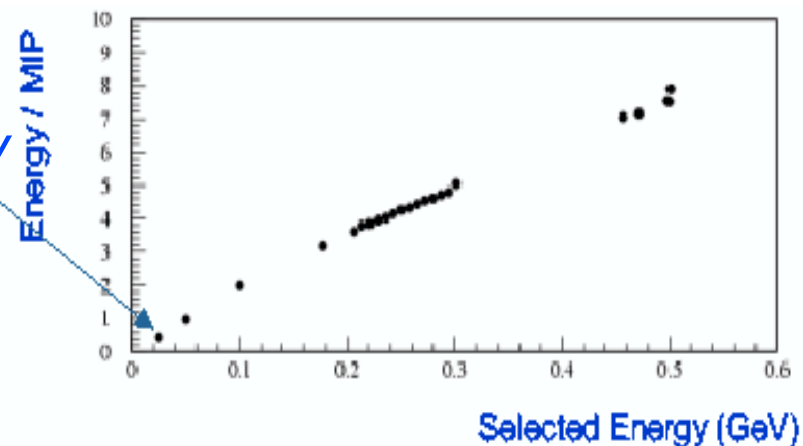

# Čerenkov beam monitor I

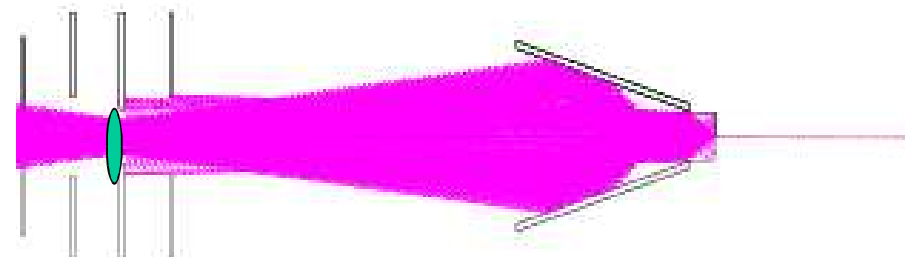
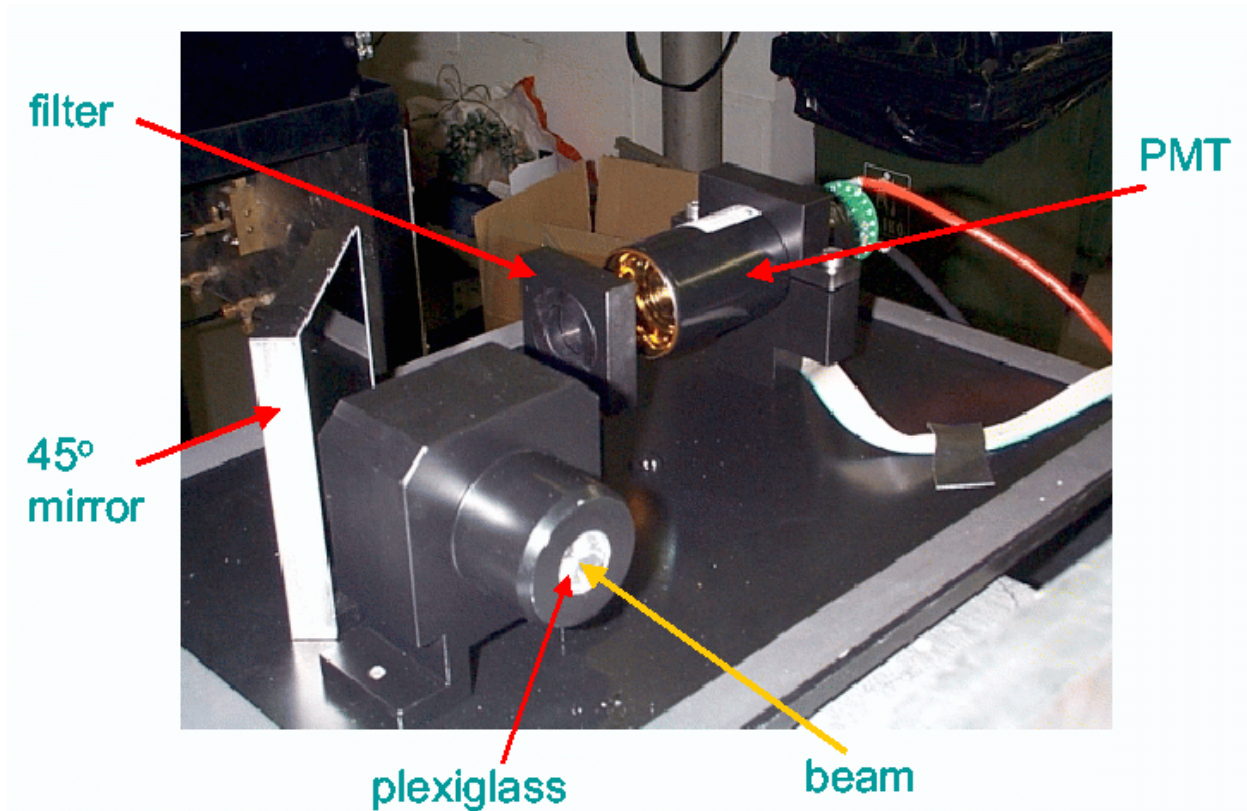

# Čerenkov beam monitor I

*No filter*

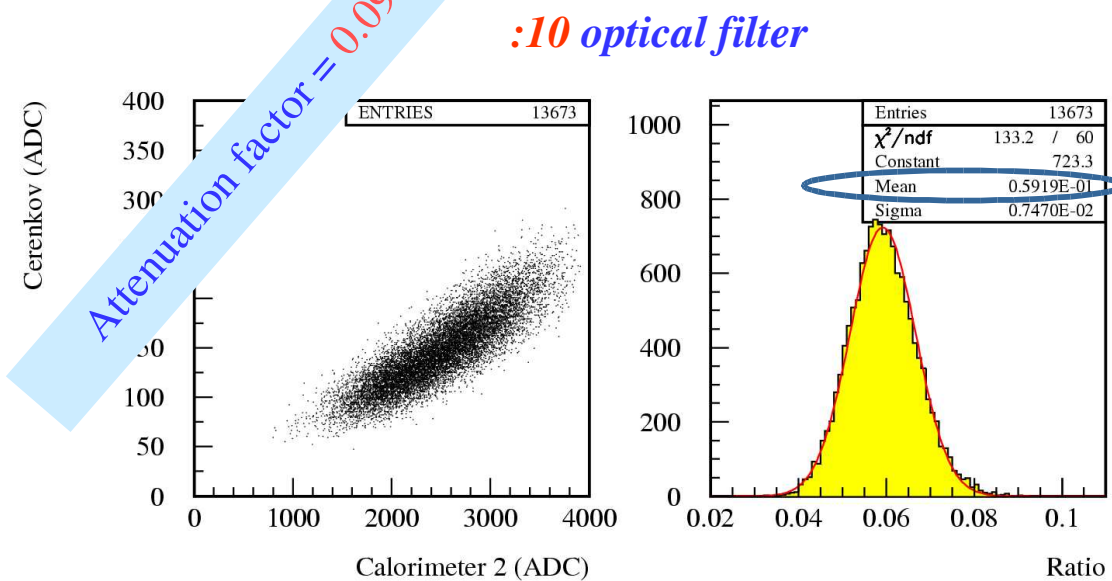
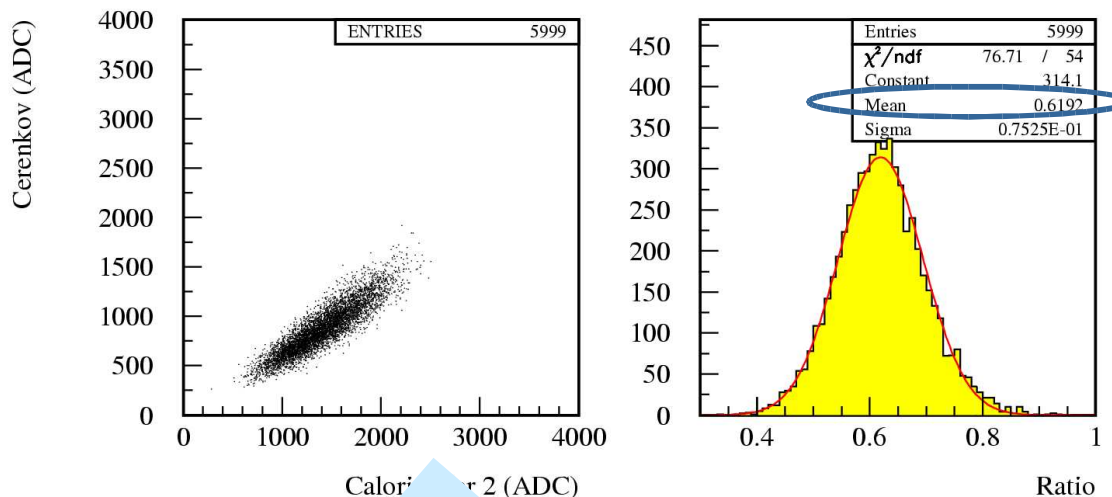

# Čerenkov beam monitor II

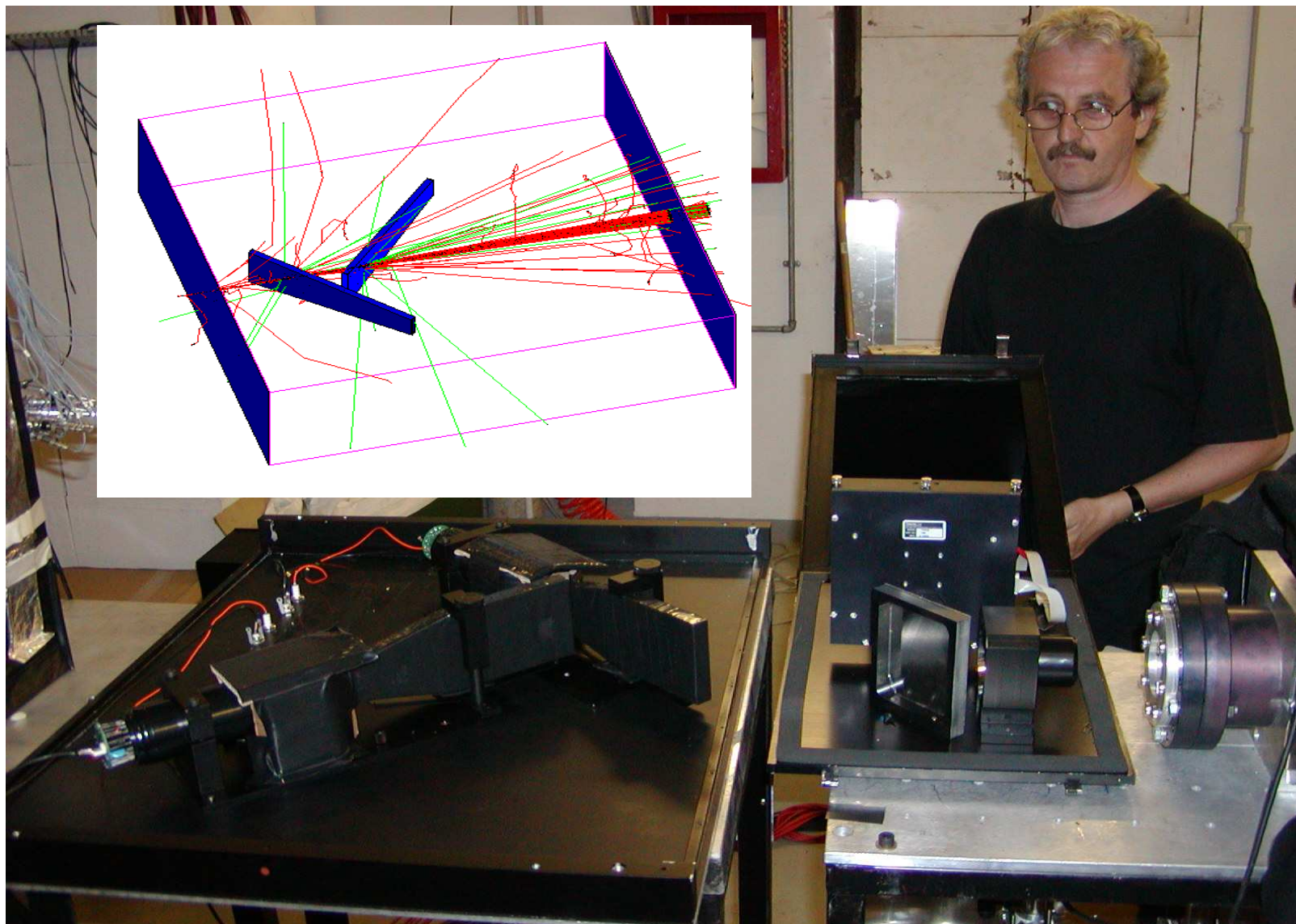

# Čerenkov beam monitor II

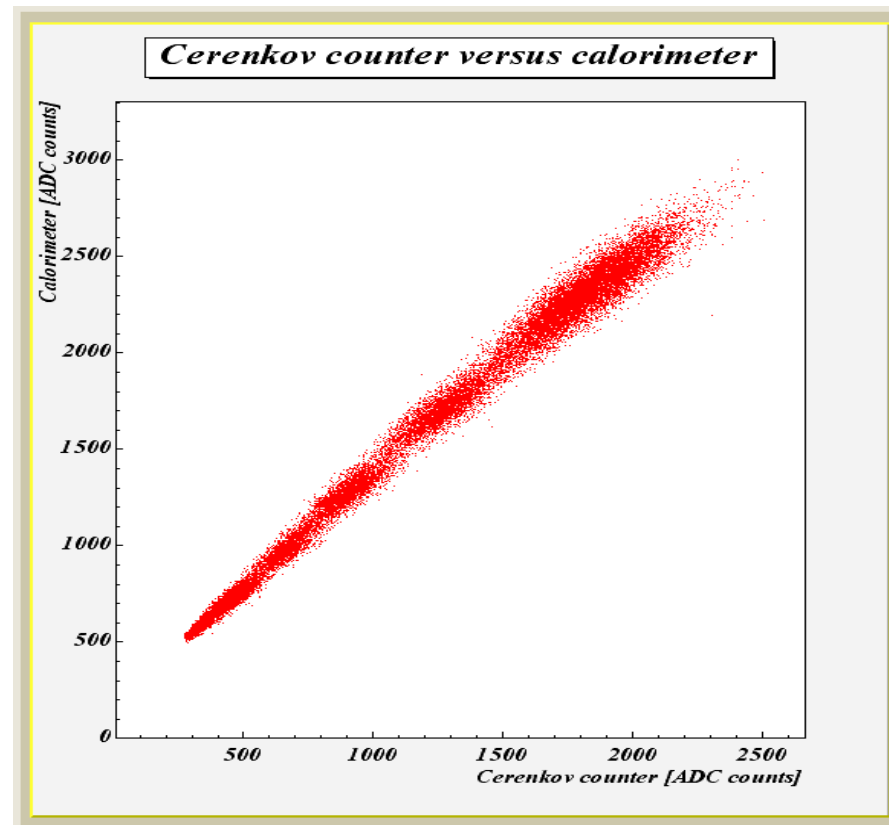
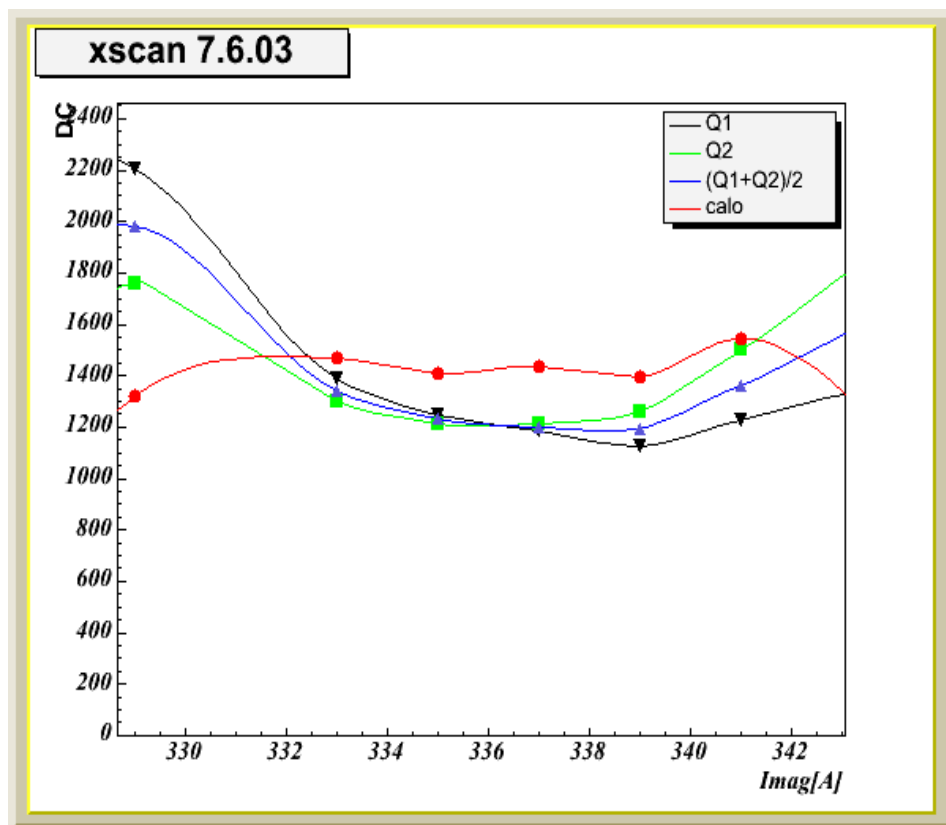

16 mm plexiglass  
 $E = 493 \text{ MeV}$

# Čerenkov beam monitor II

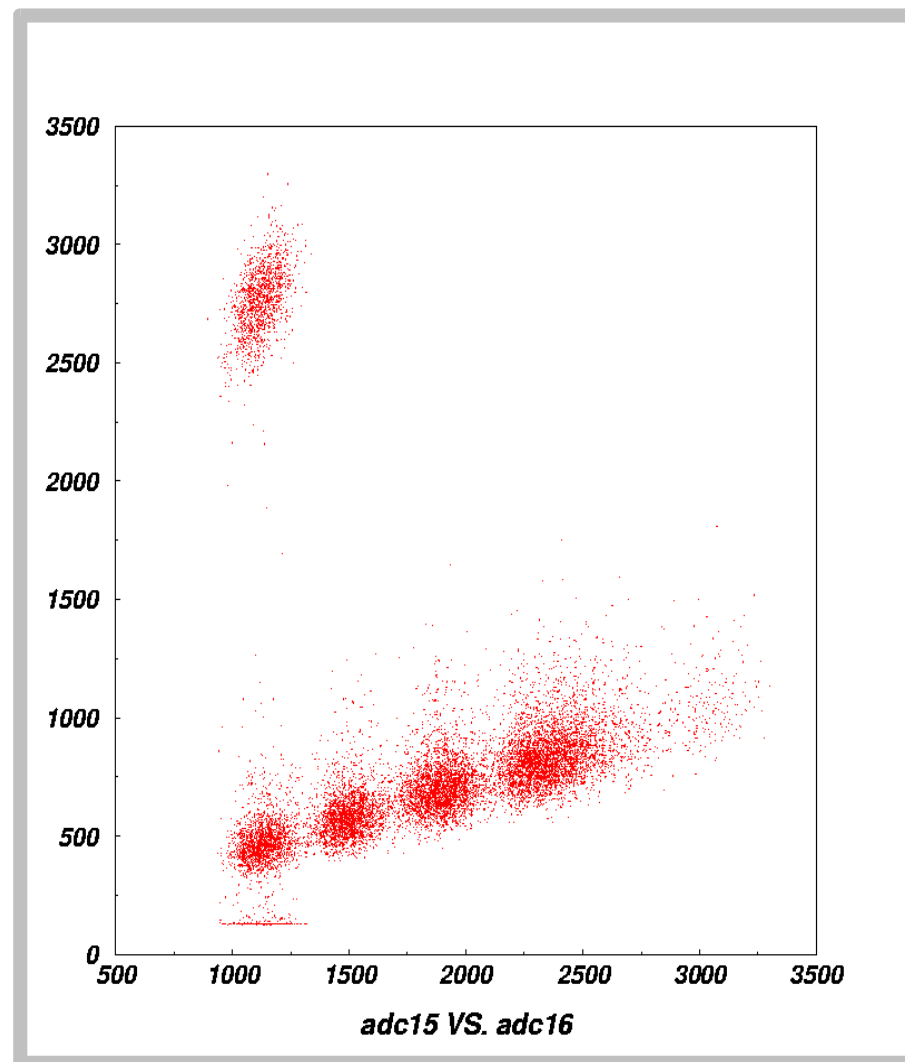
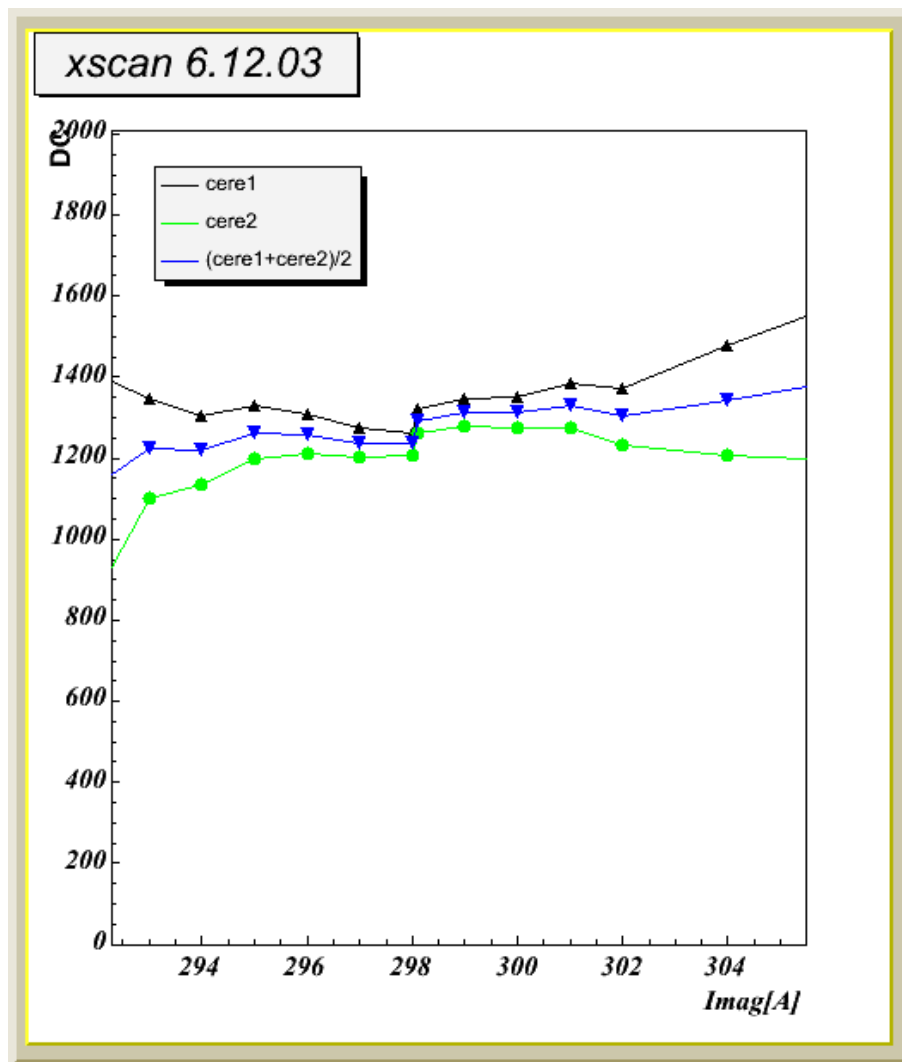

# Beam spot I

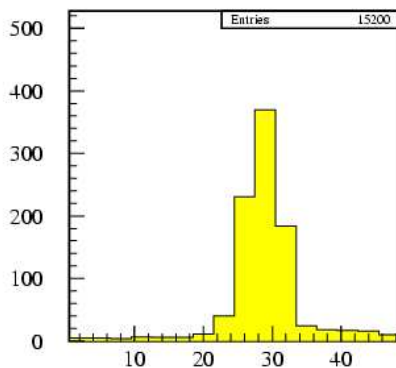

Profile (norm) H

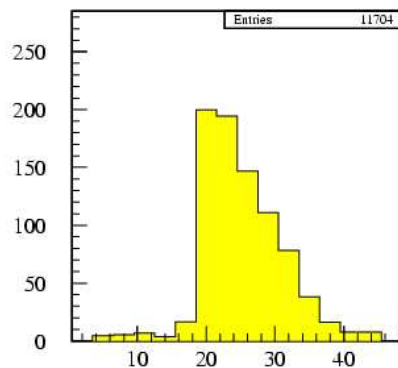

Profile (norm) V

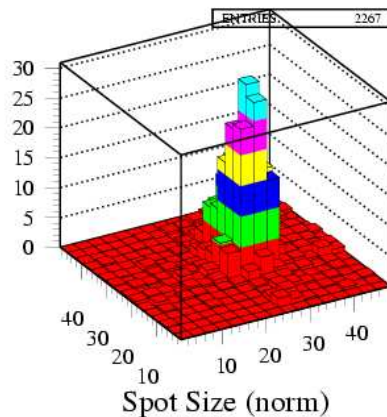

Spot Size (norm)



1 mm scintillating fibers



Multinode read out  
3x4 collected fiber, 3mm pixel

# Beam spot II

**AGILE Silicon Tracker:** 14 planes, with two Si-layers per plane providing the X and Y coordinates. 9.5 x 9.5 cm<sup>2</sup>, microstrip pitch equal to 121  $\mu\text{m}$ , and thickness 410  $\mu\text{m}$ . 384 readout channels (readout pitch equal to 242  $\mu\text{m}$ )



Few electrons, with different energies

Silicon Tracker

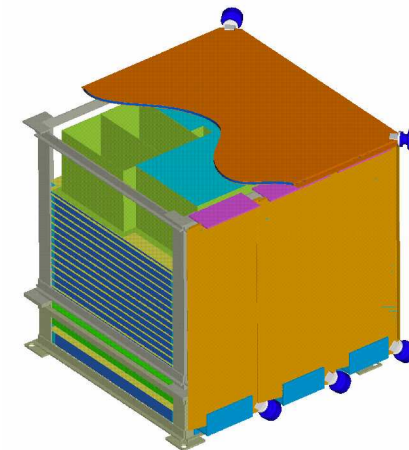

M. Boháčová  
13.12.2003

# Beam spot II

× 384 strips, analog readout

